

INSTRUCTIONS FOR ORDERING PARTS

All service parts should be ordered through your authorized H & S dealer. They will be able to give you faster service if you will provide them with the following

1. Model & Serial number is located on the front, right main frame near pole pivot of your unit.
2. All reference to left or right apply to the machine as viewed from the rear.
3. Parts should not be ordered from illustration only. Please order by complete part number.
4. If your dealer has to order parts - give shipping instructions:

VIA truck - large pieces (please specify local truck lines)

VIA United Parcel Service (include full address)

H&S MFG. CO. INC.	
MARSHFIELD, WIS.	
MOD. NO.	<input type="text"/>
SER. NO.	<input type="text"/>
DESCR.	<input type="text"/>

PLEASE RECORD NUMBERS FOR YOUR UNIT FOR QUICK REFERENCE

ABOUT IMPROVEMENTS

H&S IS CONTINUALLY STRIVING TO IMPROVE IT'S PRODUCTS

We must therefore, reserve the right to make improvements or changes whenever it becomes practical to do so without incurring any obligation to make changes or additions to the equipment previously sold.

FIGURE 1

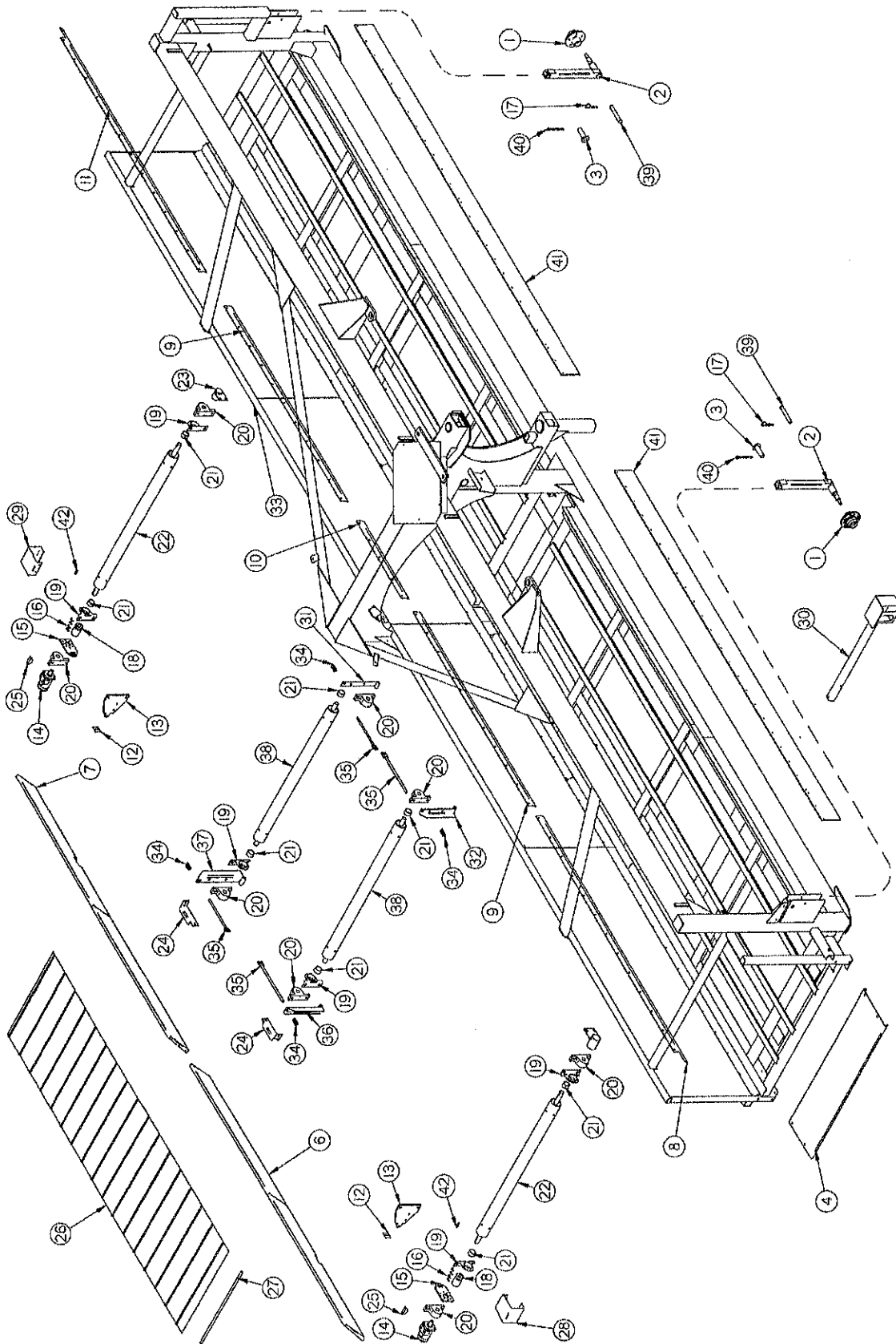

FIGURE 1
H&S 9' & 12' TWIN MERGER
MAIN FRAME

ITEM	PART NO.	DESCRIPTION	ITEM	PART NO.	DESCRIPTION
1.	SHM17	Frame Gauge Wheel Hub	16.	DWM137	Cap Screw - Coupler
*	CAT5	Seal	17.	ES7	Hair Pin
*	CAT6	Inner Bearing	18.	DWM27	Coupler
*	CAT7	Inner Race	19.	DWM36	Anti-Wrap Guard
*	CAT128A	Stud Bolt	20.	DWM132	Bearing (Pillow Block)
*	CAT14	Stud Nut	21.	DWM57	Spacers
*	CAT9	Outer Race	22.	DWM14	Drive Roller
*	CAT10	Outer Bearing	23.	DWM31	Shaft Shield
*	BFR63	Washer	24.	DWM379	Bearing Bracket
*	BFR64	Slotted Nut	25.	5B10	1/4" x 1" Woodruff Key
*	CAT13	Hub Cap	26.	DWM160	Cross Conveyor Belt
*	CAT166	18.5 x 8.50 x 8 Tire	*	DWM318	Repair Dutchman
*	CAT211	8 x 7 (5 Bolt) Wheel	27.	DWM161	Cross Conveyor Lacing Pin
*	BFR65	Cotter Key	*	DWM162	Cross Conveyor Lacing
2.	DWM411	Frame Gauge Wheel Arm	28.	DWM41	Right Motor Shield
3.	DWM409	Frame Gauge Wheel Arm Pin	29.	DWM42	Left Motor Shield
4.	CHM311	Hay Deflector	30.	DWM341	Right Rear Light Bracket
6.	DWM387	RH Wind Guard	31.	DWM23	Front Left Tightener
7.	DWM386	LH Wind Guard	32.	DWM24	Front Right Tightener
8.	DWM335	Skirt RH	33.	DWM22	Frame
9.	DWM46	Short Skirt	34.	DWM232	Spring (Blue)
10.	DWM47	Middle Skirt	35.	DWM231	Tightener
11.	DWM334	Skirt LH	36.	DWM377	RH Tightener Arm
12.	DWM45	Motor Spacer	37.	DWM378	LH Tightener Arm
13.	DWM51	Male Torque Arm	38.	DWM13	Conveyor Roller
14.	DF1	Hydraulic Motor (101-2970)	39.	DWM430	1/2" x 3-1/2" Clevis Pin
*	WM225	Seal Kit	40.	R70	3/16" x 2" Cotter Pin
15.	DWM39	Torque Arm	41.	DWM350	Poly Skirt
NOTE: * (MEANS NOT SHOWN)			42.	G23B	5/16" x 1-3/8" Key

NOTE: * (MEANS NOT SHOWN)

FIGURE 2

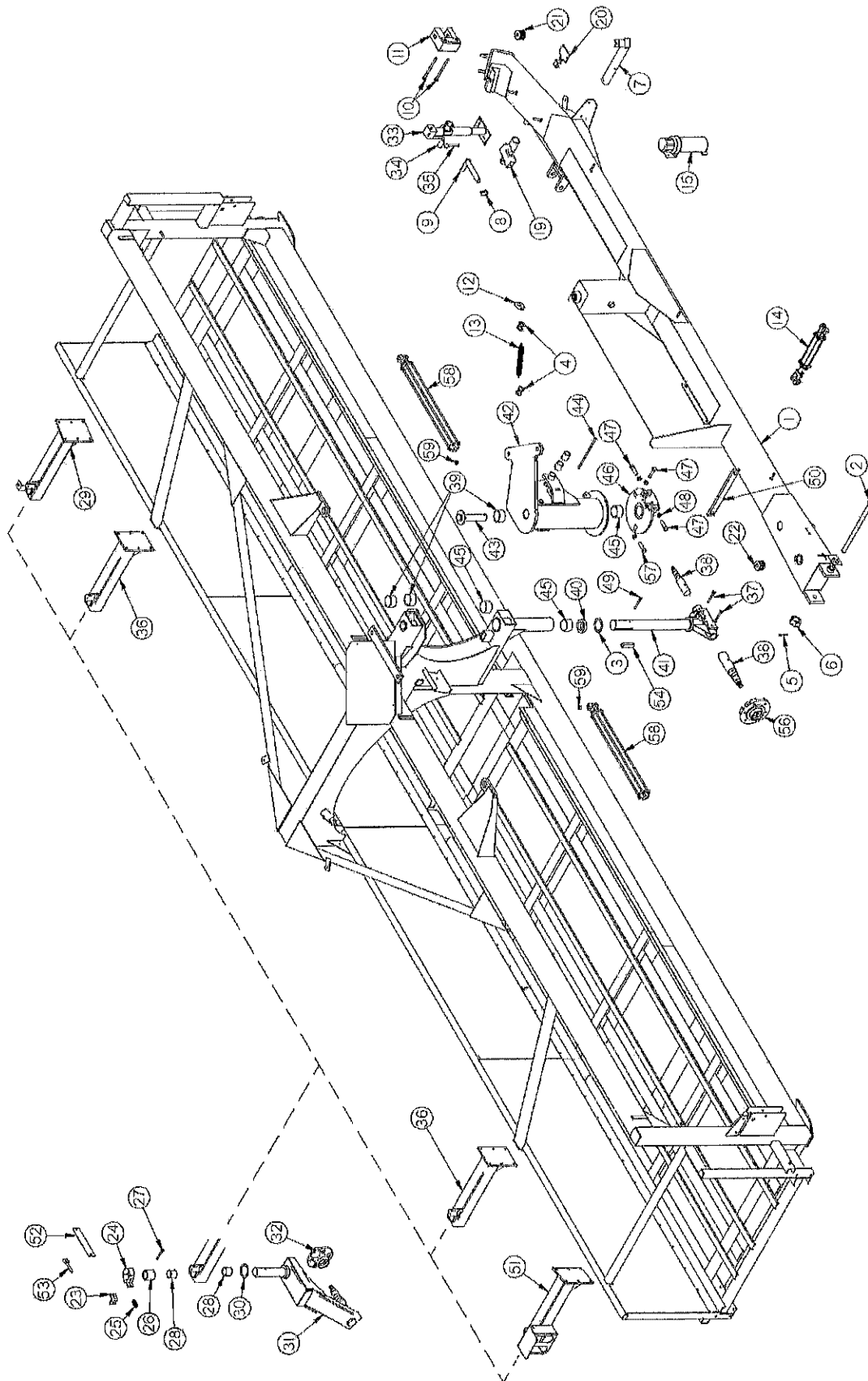

FIGURE 2
H&S 9' & 12' TWIN MERGER
POLE & STEERING

ITEM	PART NO.	DESCRIPTION	ITEM	PART NO.	DESCRIPTION
1.	DWM442	Pole	*	B31	5/32" x 1-3/4" Cotter Key
2.	DWM33	Pole Pin	33.	DWM124	Jack (2000#)
3.	DWM73	Bronze Washer 3" ID	34.	12N12	Jack Handle
4.	F87	S-Hook	35.	BFR4	Jack Pin & Chain
5.	DWM255	3/16" x 2-1/2" Cotter Key	36.	SWM3	Caster Mount
6.	BFR228	1-1/4"-12 Slotted Hex Nut	37.	DWM172	3/8" x 3-1/2" Bolt GR. 5
7.	DWM340	Light Bracket	38.	SHM34	Spindle
8.	F56	Lynch Pin	39.	RG26	Bushing (Steel)
9.	DWM34	Pole Lock Pin	40.	DWM49	Steel Washer
10.	50N129	3/4" x 6" Bolt GR. 5	41.	DWM352	Steering Fork
11.	WM43	Hitch - Adjustable	42.	DWM16	Steering Pivot
12.	DWM331	Spring Clip	43.	DWM18	Steering Pin
13.	K103	Spring	44.	DWM72	Bolt (Ready Rod)
14.	T188A	Cylinder	45.	B58	Bushing (Phenolic)
15.	S522	Manual Holder	46.	DWM17	Steering Flange
19.	DWM338	Pump Storage Bracket	47.	DWM168	3/4" x 4" Bolt Full Thread GR. 5
20.	DWM366	Module Holder	48.	DWM169	3/4" Coarse Thread Jam Nut
21.	DWM159	3/4" Black Pipe Plug	49.	DWM170	3/8" x 5" Bolt GR. 5
22.	DWM261	1" Pipe Socket Plug	50.	DWM353	Lift Bar
23.	WM211	Brake Angle	51.	DWM254	Right Tail Wheel
24.	WM286	Brake Band	52.	WM288	Brake Pad
25.	WM210	Spring (Red)	53.	WM287	I-Bolt
26.	DWM59	Brake Bushing	54.	DWM126	1/2"x2-1/2" Sq.Key w/Round Ends
27.	BFR313	5/16" x 2-3/4" Roll Pin	55.	RG132	1-1/4"ID x 2" Bushing
28.	BFR527	2"ID x 2-1/4"OD x 2" Bushing	56.	RG168	Hub
29.	DWM253	Left Tail Wheel	*	RG165	Seal
30.	RG24	2"IDx3"ODx1/8" Bronze Washer	*	RG166	Inner Bearing
31.	SHM18	Casters	*	RG167	Inner Race
32.	DWM395	Hub - Road Wheels	*	RG71	Stud Bolt
*	RG98	Seal	*	RG72	Lug Nut
*	DWM461	Inner Bearing (Timkin)	*	RG169	Outer Race
*	DWM462	Inner Race (Timkin)	*	RG170	Outer Bearing
*	RG102	Stud Bolt	*	RG183	Washer (Hardened)
*	BFR144	Nut	*	RG185	Cotter Pin
*	DWM463	Outer Race (Timkin)	*	RG184	Nut
*	DWM464	Outer Bearing (Timkin)	*	RG171	Hub Cap
*	DWM121	Washer (Hardened)	*	CHM102	Wheel
*	RG103	Hub Cap	*	CHM327	13.50 x 15FI Tire
*	DWM451	Wheel (Rear)	57.	DWM173	3/4"x2-1/2" Full Thread Bolt GR. 5
*	DWM163	11Lx15 Rear Tire	58.	DWM406	3-1/2" x 30" Cylinder
*	B3	7/8" Slotted Nut	59.	DWM141	Spacer 1/2"

NOTE: * (MEANS NOT SHOWN)

FIGURE 3

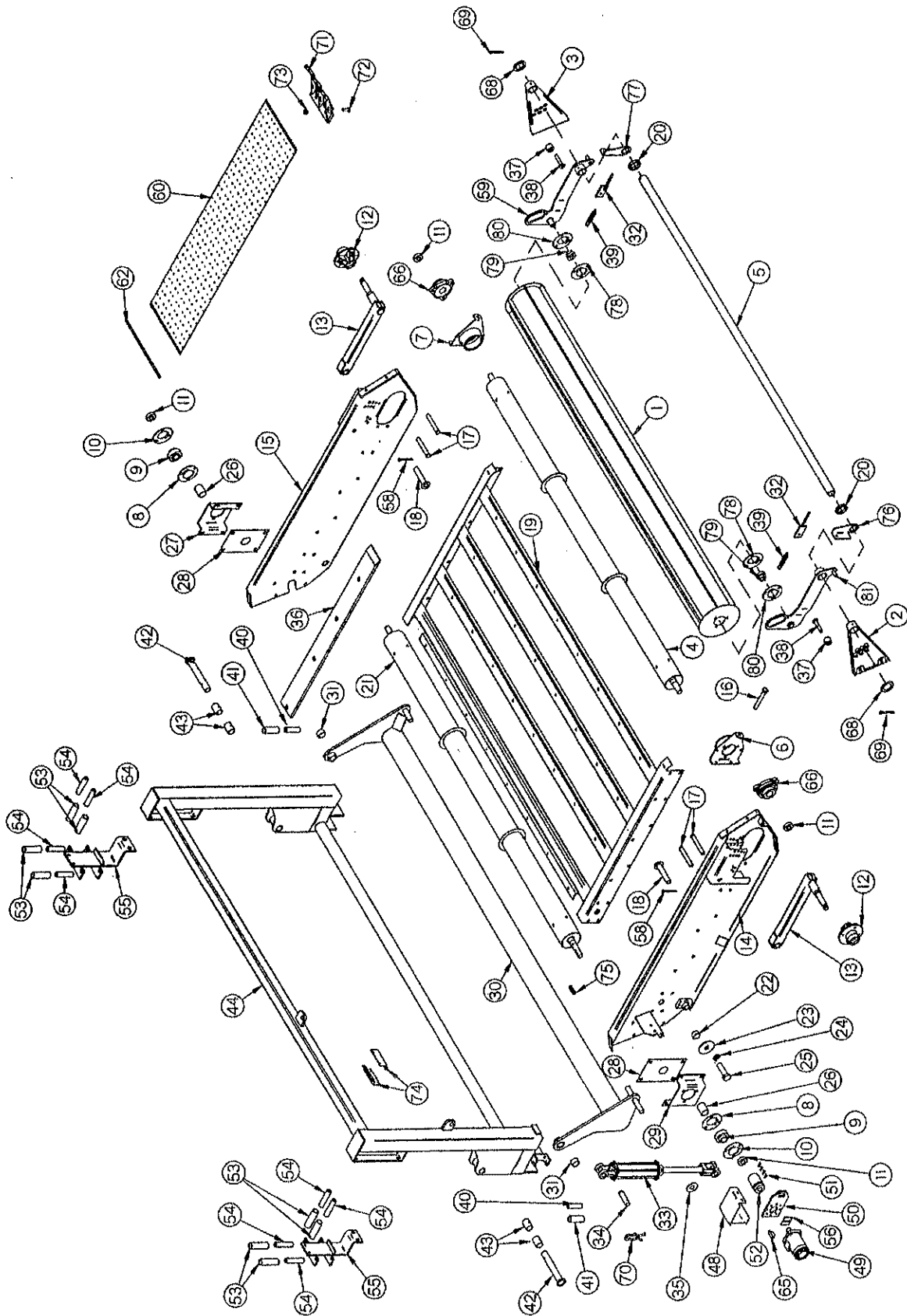
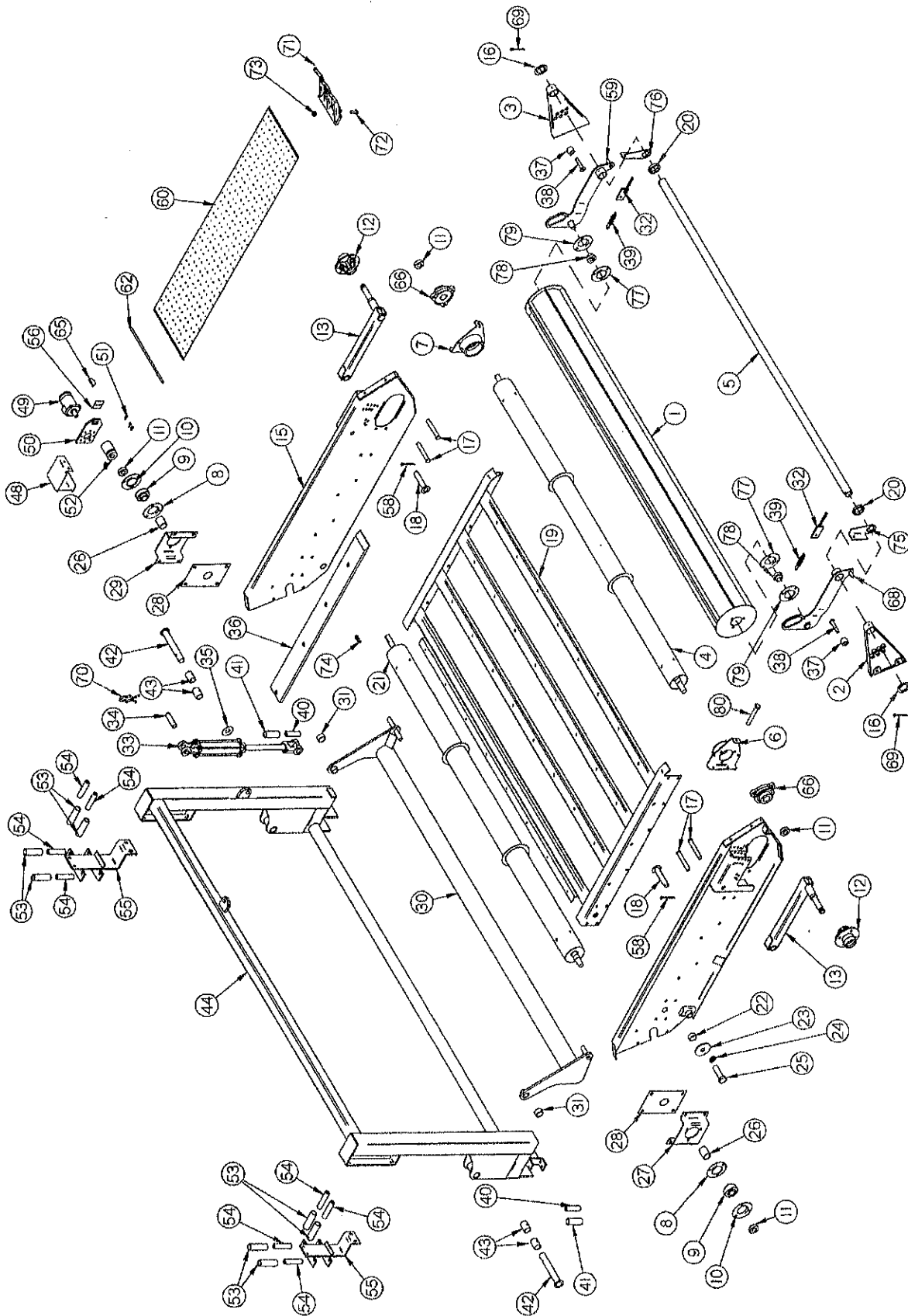

FIGURE 3
H&S 9' TWIN MERGER
LEFT PICK-UP HEAD

ITEM	PART NO.	DESCRIPTION	ITEM	PART NO.	DESCRIPTION
1.	WM356	9' Crop Roller	34.	T143	Cylinder Pin
2.	WM350	Right Bracket	35.	16SV136	Washer
3.	WM351	Left Bracket	36.	DWM358	Slides
4.	WM342	Front Idler Roller	37.	WM353	Poly Bumper
5.	WM357	Front Support	38.	WM354	Adjustment Pin
6.	WM179	Right Roller Adjustment Bracket	39.	ST36	Spring
7.	WM192	Left Roller Adjustment Bracket	40.	DWM55	Short Slider Spacer
8.	F145	Flange	41.	DWM67	Short Back Slider Roller
9.	WM29	Bearing	42.	DWM21	Head Pin
10.	F143	Flange (Greaseable)	43.	RG132	1-1/4"ID x 2" Bushing
11.	WM27	1-1/4" Lock Collar w/Set Screw	44.	DWM375	Left Head Slide
12.	CAT177	Hub - Complete	48.	DWM43	Left Head Shield
*	CAT135A	Seal	49.	DWM84	Hydraulic Motor (101-3048)
*	CAT10	Bearing (2)	*	WM225	Seal Kit
*	CAT9	Race (2)	50.	DWM39	Hydraulic Motor Mount
*	CAT136A	Hub w/Races	51.	DWM137	Cap Screw - Coupler
*	CAT128	Stud	52.	DWM27	Coupler
*	BFR144	Lug Nut	53.	DWM66	Back Slider Roller
*	BFR65	Cotter Pin	54.	DWM54	Slider Spacer
*	CAT13	Hub Cap	55.	DWM32	Hanger Slide
*	CAT211	8 x 7 Wheel (5-Bolt)	56.	DWM45	Motor Spacer
*	CAT166	18.5 x 8.5 x 8 Tire	58.	R70	3/16" x 2" Cotter Pin
*	CAT12	Spindle Nut	59.	WM348	Left Arm
*	CAT52	Tire/Wheel Assembly	60.	DWM359A	Pick-up Belt Section
13.	DWM229	Gauge Arms	*	✓ DWM364A	Complete Belt w/Teeth & Pin
14.	DWM344	Left Head - Right Panel	*	DWM367	Repair Dutchman Assembly
15.	DWM345	Left Head - Left Panel	*	DWM373	Complete Dutchman Repair Kit
16.	LW131	1/2" x 3-1/2" Bolt GR.5			w/Nuts, Bolts and Clips
17.	DWM127	1/2" x 5" Clevis Pins	62.	SWM41	Lacing Pin
18.	DWM7	Pivot Pin	65.	5B10	1/4" x 1" Woodruff Key
19.	DWM339	Z-Channel Frame	66.	SWM35	3-Bolt Bearing Assembly
20.	WM347	Collar	68.	DWM227	Wind Guard Washer
21.	WM341	Head Drive Roller	69.	SWM55	1/4" x 2-1/2" Cotter Pin
22.	WM183	Pivot Bushing	70.	T144	Clip Pins
23.	WM218	Washer	71.	SWM1	Pick-up Tooth
24.	DWM171	1" Lock Washer	72.	SWM26	Bolt
25.	DWM177	1" x 2-1/2" Bolt Full Thread GR.5	73.	SWM27	Nut
26.	WM343	Spacer PVC	74.	DWM380	Cylinder Stop
27.	WM186	Bearing Bracket LH	75.	G23B	5/16" x 1-3/8" Key
28.	WM180	Side Panel Slot Plate	76.	WM362	RH Spring Tightener Bracket
29.	WM187	Bearing Bracket RH	77.	WM363	LH Spring Tightener Bracket
30.	DWM10	Left Pick-up Lifter	78.	F14	Bearing Flange
31.	DWM57	Spacer	79.	F115	1-1/4" Bearing
32.	12V78	Tightener Bracket	*	F16	1-1/4" Lock Collar
33.	BFR69A	Hydraulic Cylinder	80.	F114A	Bearing Flange w/45° Zerk
*	X94	Cylinder Spacer 5/16"			

NOTE: * (MEANS NOT SHOWN)

FIGURE 4



**FIGURE 4
H&S 9' TWIN MERGER
RIGHT PICK-UP HEAD**

ITEM	PART NO.	DESCRIPTION	ITEM	PART NO.	DESCRIPTION
1.	WM356	9' Crop Roller	34.	T143	Cylinder Pin
2.	WM350	Right Bracket	35.	16SV136	Washer
3.	WM351	Left Bracket	36.	DWM358	Slides
4.	WM342	Front Idler Roller	37.	WM353	Poly Bumper
5.	WM357	Front Support	38.	WM354	Adjustment Pin
6.	WM179	Right Roller Adjustment Bracket	39.	ST36	Spring
7.	WM192	Left Roller Adjustment Bracket	40.	DWM55	Short Slider Spacer
8.	F145	Flange	41.	DWM67	Short Back Slider Roller
9.	WM29	Bearing	42.	DWM21	Head Pin
10.	F143	Flange (Greaseable)	43.	RG132	1-1/4"ID x 2" Bushing
11.	WM27	1-1/4" Lock Collar w/Set Screw	44.	DWM376	Right Head Slide
12.	CAT177	Hub - Complete	48.	DWM40	Right Head Shield
*	CAT135A	Seal	49.	DWM84	Hydraulic Motor (101-3048)
*	CAT10	Bearing (2)	*	WM225	Seal Kit
*	CAT9	Race (2)	50.	DWM39	Hydraulic Motor Mount
*	CAT136A	Hub w/Races	51.	DWM137	Cap Screw - Coupler
*	CAT128	Stud	52.	DWM27	Coupler
*	BFR144	Lug Nut	53.	DWM66	Back Slider Roller
*	BFR65	Cotter Pin	54.	DWM54	Slider Spacer
*	CAT13	Hub Cap	55.	DWM32	Hanger Slide
*	CAT211	8 x 7 Wheel (5-Bolt)	56.	DWM45	Motor Spacer
*	CAT166	18.5 x 8.5 x 8 Tire	58.	R70	3/16" x 2" Cotter Pin
*	CAT12	Spindle Nut	59.	WM348	Left Arm
*	CAT52	Tire/Wheel Assembly	60.	DWM359A	Pick-up Belt Section
13.	DWM229	Gauge Arms	*	DWM364A	Complete Belt w/Teeth & Pin
14.	DWM342	Right Head - Right Panel	*	DWM367	Repair Dutchman Assembly
15.	DWM343	Right Head - Left Panel	*	DWM373	Complete Dutchman Repair Kit w/Nuts, Bolts and Clips
16.	DWM227	Wind Guard Washer			
17.	DWM127	1/2" x 5" Clevis Pins	62.	SWM41	Lacing Pin
18.	DWM7	Pivot Pin	65.	5B10	1/4" x 1" Woodruff Key
19.	DWM339	Z-Channel Frame	66.	SWM35	3-Bolt Bearing Assembly
20.	WM347	Collar	68.	WM349	Right Arm
21.	WM341	Head Drive Roller	69.	SWM55	1/4" x 2-1/2" Cotter Pin
22.	WM183	Pivot Bushing	70.	T144	Clip Pins
23.	WM218	Washer	71.	SWM1	Pick-up Tooth
24.	DWM171	1" Lock Washer	72.	SWM26	Bolt
25.	DWM177	1" x 2-1/2" Bolt Full Thread GR. 5	73.	SWM27	Nut
26.	WM343	Spacer PVC	74.	G23B	5/16" x 1-3/8" Key
27.	WM187	Bearing Bracket RH	75.	WM362	RH Spring Tightener Bracket
28.	WM180	Side Panel Slot Plate	76.	WM363	LH Spring Tightener Bracket
29.	WM186	Bearing Bracket LH	77.	F14	Bearing Flange
30.	DWM9	Right Pick-up Lifter	78.	F115	1-1/4" Bearing
31.	DWM57	Spacer	*	F16	1-1/4" Lock Collar
32.	12V78	Tightener Bracket	79.	F114A	Bearing Flange w/45° Zerk
33.	BFR69A	Hydraulic Cylinder	80.	LW131	1/2" x 3-1/2" Bolt GR. 5
*	X94	Cylinder Spacer 5/16"			

NOTE: * (MEANS NOT SHOWN)

FIGURE 5

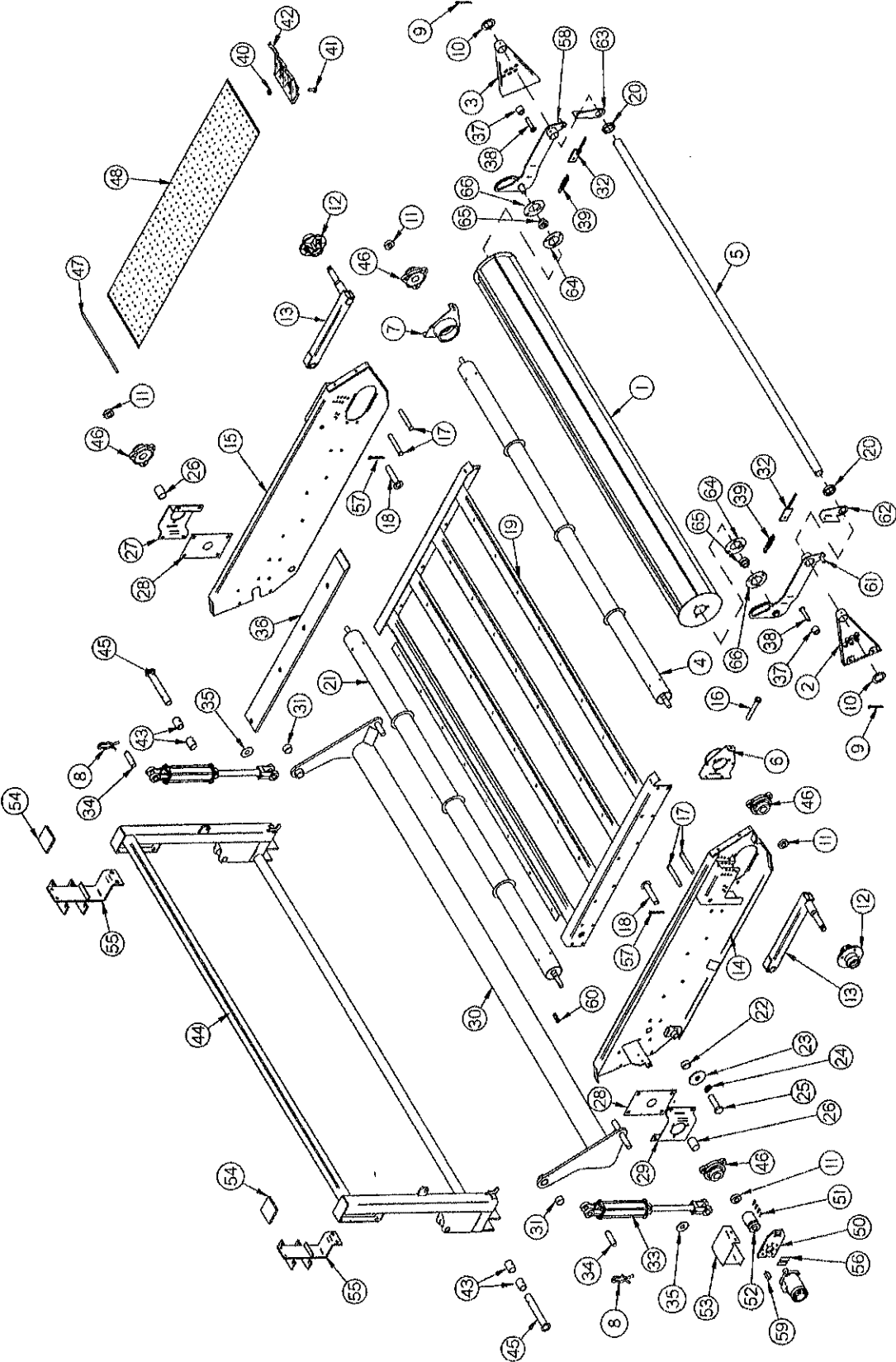

FIGURE 5
H&S 12' TWIN MERGER
LEFT PICK-UP HEAD

ITEM	PART NO.	DESCRIPTION	ITEM	PART NO.	DESCRIPTION
1.	WM352	12' Crop Roller	31.	DWM57	Spacer
2.	WM350	Right Bracket	32.	12V78	Tightener Bracket
3.	WM351	Left Bracket	33.	BFR69A	Hydraulic Cylinder
4.	SHM21	Front Idler Roller	*	X94	Cylinder Spacer 5/16"
5.	WM346	Front Support	34.	T143	Cylinder Pin
6.	WM179	Right Roller Adjustment Bracket	35.	16SV136	Washer
7.	WM192	Left Roller Adjustment Bracket	36.	DWM358	Slides
8.	T144	Clip Pins	37.	WM353	Poly Bumper
9.	SWM55	1/4" x 2-1/2" Cotter Pin	38.	WM354	Adjustment Pin
10.	DWM227	Wind Guard Washer	39.	ST36	Spring
11.	WM27	1-1/4" Lock Collar w/Set Screw	40.	SWM27	Nut
12.	CAT177	Hub - Complete	41.	SWM26	1" x 2-1/2" Bolt Full Thread GR. 5
*	CAT135A	Seal	42.	SWM1	Pickup Tooth
*	CAT10	Bearing (2)	43.	RG132	1-1/4"ID x 2" Bushing
*	CAT9	Race (2)	44.	SHM7	Head Mount
*	CAT136A	Hub w/Races	45.	DWM21	Head Pin
*	CAT128	Stud	46.	SWM35	3-Bolt Bearing Assembly
*	BFR144	Lug Nut	47.	SWM41	Lacing Pin
*	BFR65	Cotter Pin	48.	DWM359A	Pickup Belt Section
*	CAT13	Hub Cap	*	DWM364A	Complete Belt w/Teeth & Pin
*	CAT211	8 x 7 Wheel (5-Bolt)	*	DWM367	Repair Dutchman Assembly
*	CAT166	18.5 x 8.5 x 8 Tire	*	DWM373	Complete Dutchman Repair Kit w/Nuts, Bolts and Clips
*	CAT12	Spindle Nut	49.	DWM84	Hydraulic Motor (101-3048)
*	CAT52	Tire/Wheel Assembly	*	WM225	Seal Kit
13.	DWM229	Gauge Arms	50.	DWM39	Hydraulic Motor Mount
14.	DWM344	Left Head - Right Panel	51.	DWM137	Cap Screw - Coupler
15.	DWM345	Left Head - Left Panel	52.	DWM27	Coupler
16.	LW131	1/2" x 3-1/2" Bolt GR. 5	53.	DWM43	Left Head Shield
17.	DWM127	1/2" x 5" Clevis Pins	54.	SHM10	Head Spacer
18.	DWM7	Pivot Pin	55.	DWM32	Hanger Slide
19.	SHM4	Z-Channel Frame	56.	DWM45	Motor Spacer
20.	WM347	Collar	57.	R70	3/16" x 2" Cotter Pin
21.	SHM22	Head Drive Roller	58.	WM348	Left Arm
22.	WM183	Pivot Bushing	59.	5B10	1/4" x 1" Woodruff Key
23.	WM218	Washer	60.	G23B	5/16" x 1-3/8" Key
24.	DWM171	1" Lock Washer	61.	WM349	Right Arm
25.	DWM177	1" x 2-1/2" Bolt Full Thread GR. 5	62.	WM362	RH Spring Tightener Bracket
26.	SHM23	Spacer PVC	63.	WM363	LH Spring Tightener Bracket
27.	SHM12	Bearing Bracket LH	64.	F14	Bearing Flange
28.	WM180	Side Panel Slot Plate	65.	F115	1-1/4" Bearing
29.	SHM13	Bearing Bracket RH	*	F16	1-1/4" Lock Collar
30.	SHM8	Pickup Lifter	66.	F114A	Bearing Flange w/45° Zerk

NOTE: * (MEANS NOT SHOWN)

FIGURE 6

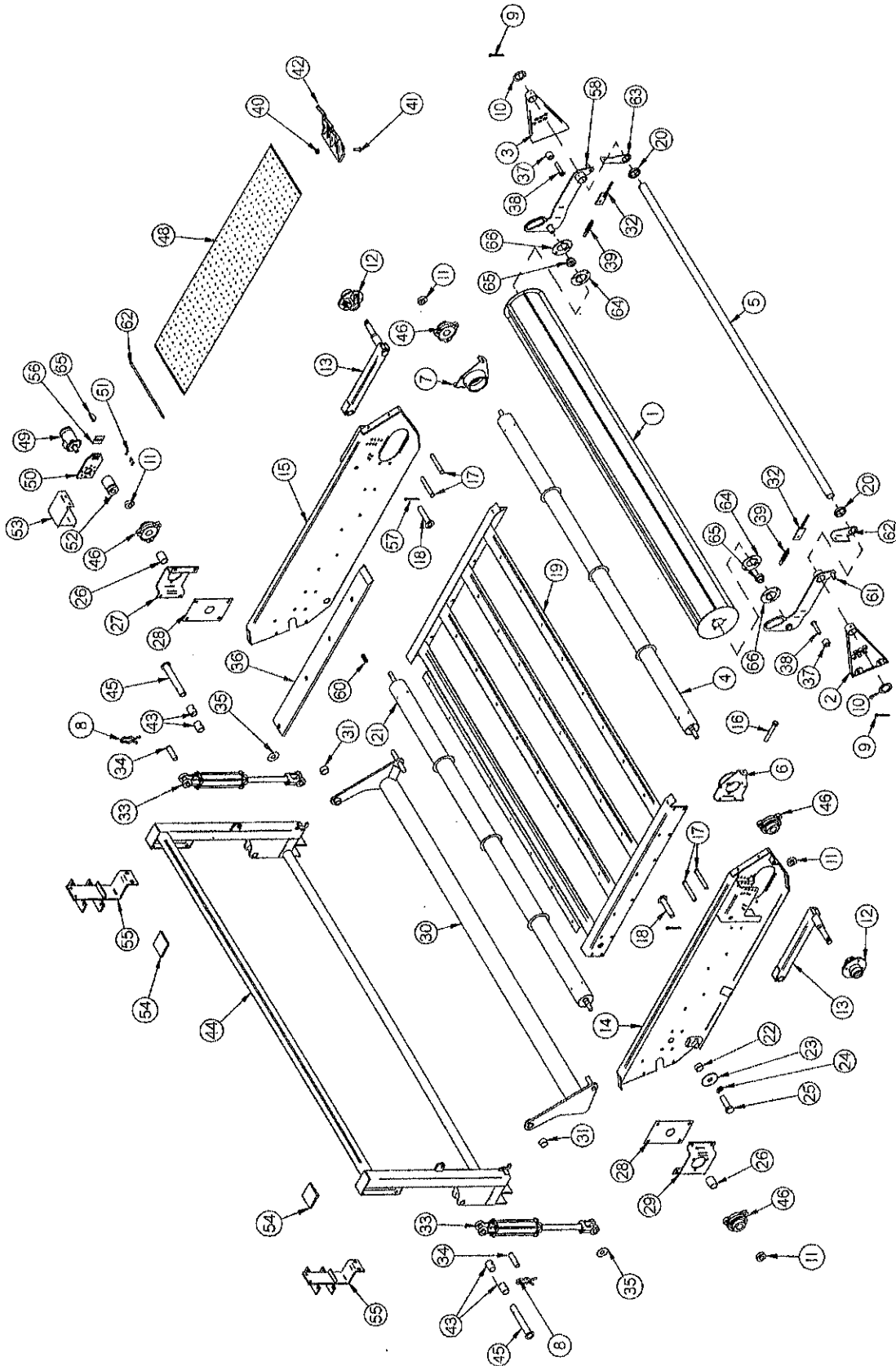

FIGURE 6
H&S 12' TWIN MERGER
RIGHT PICK-UP HEAD

ITEM	PART NO.	DESCRIPTION	ITEM	PART NO.	DESCRIPTION
1.	WM352	12' Crop Roller	31.	DWM57	Spacer
2.	WM350	Right Bracket	32.	12V78	Tightener Bracket
3.	WM351	Left Bracket	33.	BFR69A	Hydraulic Cylinder
4.	SHM21	Front Idler Roller	*	X94	Cylinder Spacer 5/16"
5.	WM346	Front Support	34.	T143	Cylinder Pin
6.	WM179	Right Roller Adjustment Bracket	35.	16SV136	Washer
7.	WM192	Left Roller Adjustment Bracket	36.	DWM358	Slides
8.	T144	Clip Pins	37.	WM353	Poly Bumper
9.	SWM55	1/4" x 2-1/2" Cotter Pin	38.	WM354	Adjustment Pin
10.	DWM227	Wind Guard Washer	39.	ST36	Spring
11.	WM27	1-1/4" Lock Collar w/Set Screw	40.	SWM27	Nut
12.	CAT177	Hub - Complete	41.	SWM26	Bolt
*	CAT135A	Seal	42.	SWM1	Pickup Tooth
*	CAT10	Bearing (2)	43.	RG132	1-1/4"ID x 2" Bushing
*	CAT9	Race (2)	44.	SHM7	Head Mount
*	CAT136A	Hub w/Races	45.	DWM21	Head Pin
*	CAT128	Stud	46.	SWM35	3-Bolt Bearing Assembly
*	BFR144	Lug Nut	47.	SWM41	Lacing Pin
*	BFR65	Cotter Pin	48.	DWM359A	Pickup Belt Section
*	CAT13	Hub Cap	*	DWM364A	Complete Belt w/Teeth & Pin
*	CAT211	8 x 7 Wheel (5-Bolt)	*	DWM367	Repair Dutchman Assembly
*	CAT166	18.5 x 8.5 x 8 Tire	*	DWM373	Complete Dutchman Repair Kit w/Nuts, Bolts and Clips
*	CAT12	Spindle Nut	49.	DWM84	Hydraulic Motor (101-3048)
*	CAT52	Tire/Wheel Assembly	*	WM225	Seal Kit
13.	DWM229	Gauge Arms	50.	DWM39	Hydraulic Motor Mount
14.	DWM342	Right Head - Right Panel	51.	DWM137	Cap Screw - Coupler
15.	DWM343	Right Head - Left Panel	52.	DWM27	Coupler
16.	LW131	1/2" x 3-1/2" Bolt GR. 5	53.	DWM40	Right Head Shield
17.	DWM127	1/2" x 5" Clevis Pins	54.	SHM10	Head Spacer
18.	DWM7	Pivot Pin	55.	DWM32	Hanger Slide
19.	SHM4	Z-Channel Frame	56.	DWM45	Motor Spacer
20.	WM347	Collar	57.	R70	3/16" x 2" Cotter Pin
21.	SHM22	Head Drive Roller	58.	WM348	Left Arm
22.	WM183	Pivot Bushing	59.	5B10	1/4" x 1" Woodruff Key
23.	WM218	Washer	60.	G23B	5/16" x 1-3/8" Key
24.	DWM171	1" Lock Washer	61.	WM349	Right Arm
25.	DWM177	1" x 2-1/2" Bolt Full Thread GR. 5	62.	WM362	RH Spring Tightener Bracket
26.	SHM23	Spacer PVC	63.	WM363	LH Spring Tightener Bracket
27.	SHM12	Bearing Bracket LH	64.	F14	Bearing Flange
28.	WM180	Side Panel Slot Plate	65.	F115	1-1/4" Bearing
29.	SHM13	Bearing Bracket RH	*	F16	1-1/4" Lock Collar
30.	SHM8	Pick-up Lifter	66.	F114A	Bearing Flange w/45° Zerk

NOTE: * (MEANS NOT SHOWN)

FIGURE 7

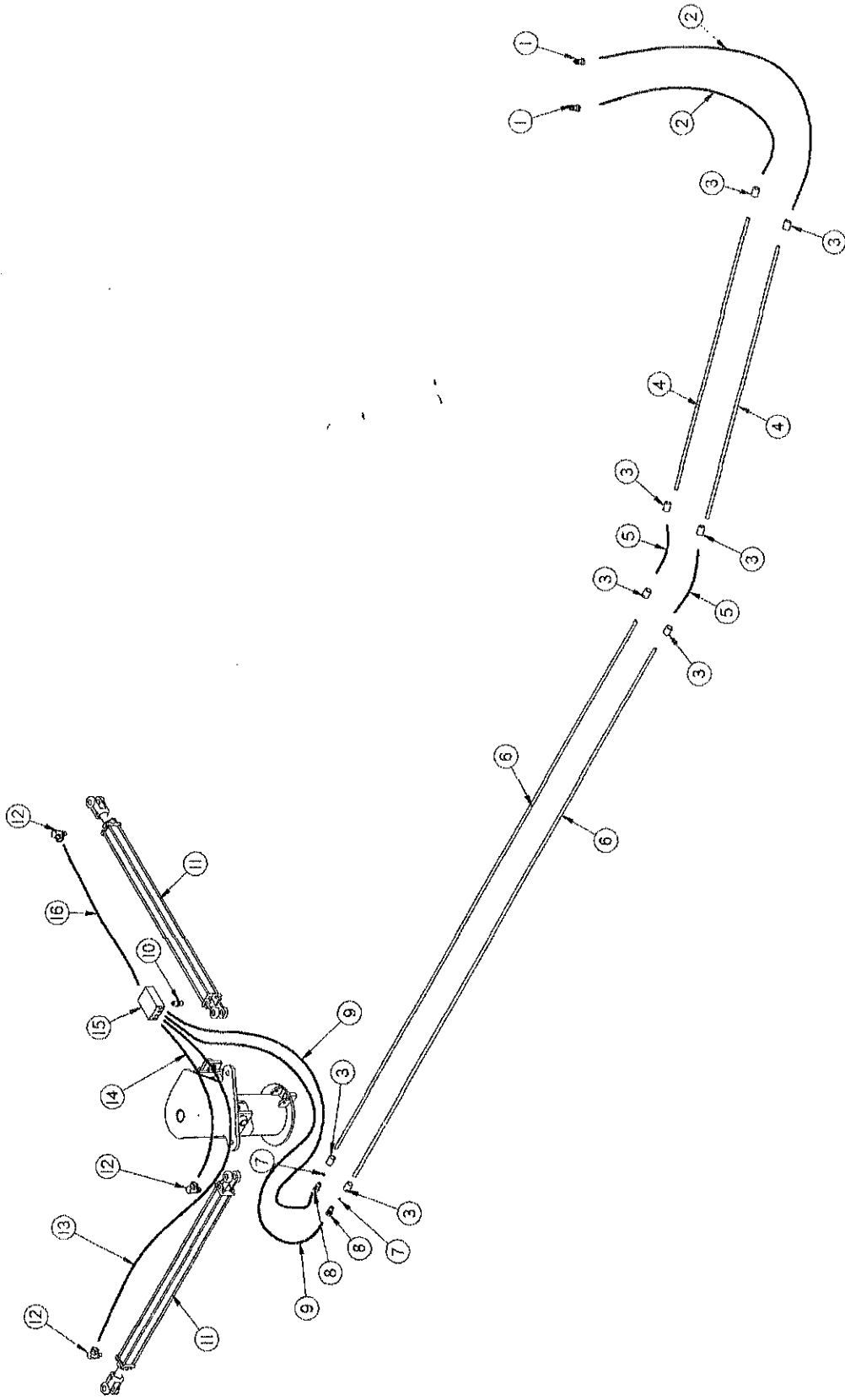

FIGURE 7
H&S 9' & 12' TWIN MERGER
POLE CIRCUIT HYDRAULICS

ITEM	PART NO.	DESCRIPTION
1.	DWM205	1/2" Quick Male Couplers
2.	DWM85	Hydraulic Hose 1/4" x 78" 3/8"MP & 1/2" MP
3.	HE60	3/8" Pipe Coupler
4.	DWM63	Short Pole Pipe
5.	DWM154	Hydraulic Hose 1/4" x 24" 3/8"MP & 3/8"MP
6.	DWM62	Long Pole Pipe
7.	DWM135	Orifice .094
8.	BFR122	3/8" Union Adapter
9.	DWM92	Hydraulic Hose 1/4" x 30" 3/8"MP & 3/8"MP
10.	WM141	1/2" Nipple Nut
11.	DWM406	3-1/2" x 30" Hydraulic Cylinder
12.	DWM415	1/2" 90° Swivel Adapter
13.	DWM428	Hydraulic Hose 1/2" x 55" 1/2"MP & 1/2"MP
14.	DWM429	Hydraulic Hose 1/2" x 22" 1/2"MP & 1/2"MP
15.	DWM414	Pole Locking and Relieving Valve
16.	DWM106	Hydraulic Hose 1/2" x 33" 1/2"MP & 1/2"MP

FIGURE 8

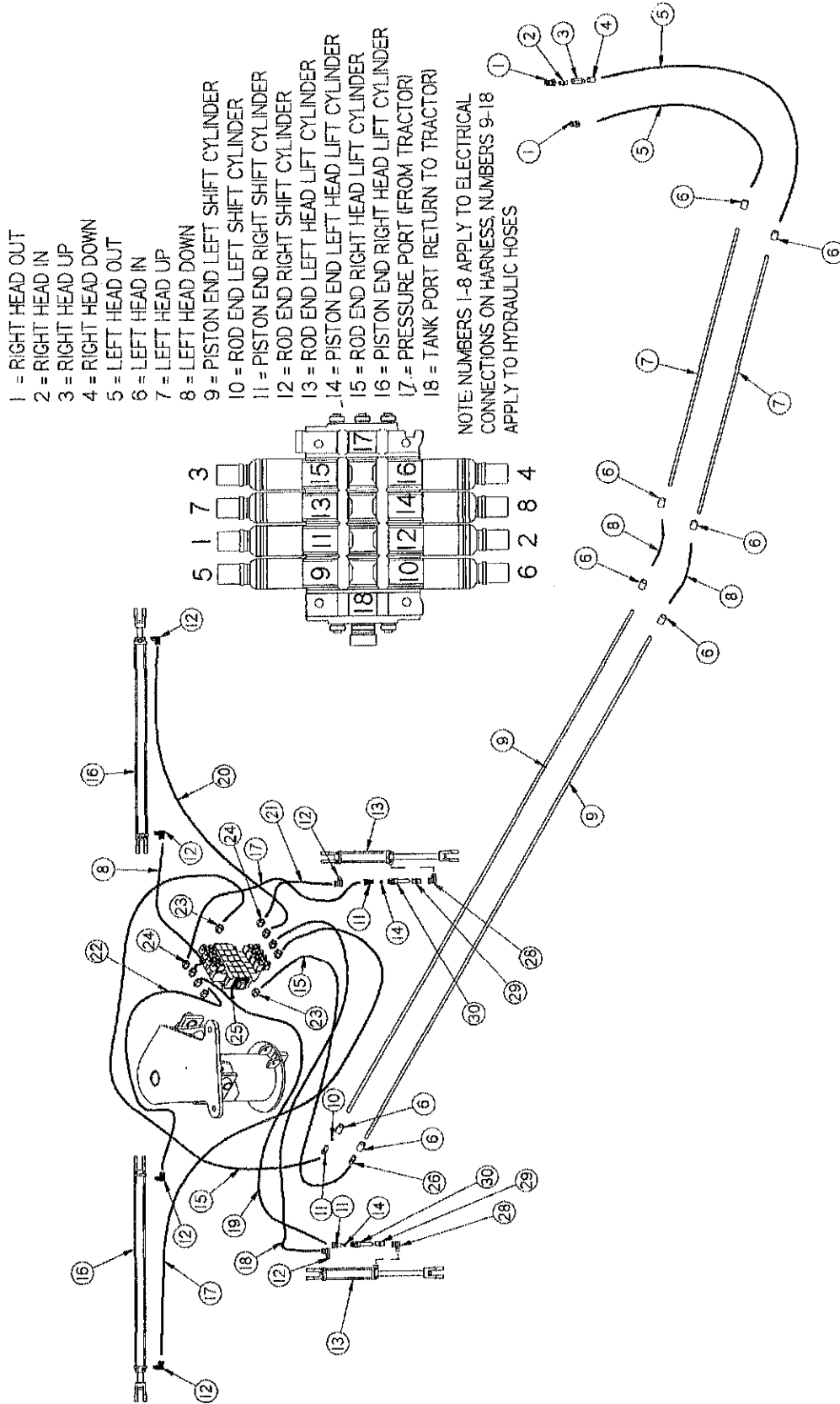

FIGURE 8
H&S 9' TWIN MERGER
ELECTRIC HEAD HYDRAULICS

ITEM	PART NO.	DESCRIPTION
1.	DWM205	1/2" Male Quick Coupler
2.	WM141	1/2" Nipple Nut
3.	DF18	1/2" Check Valve
4.	LW346	1/2" Coupler
5.	DWM85	Hydraulic Hose 1/4" x 78" 3/8"MP & 1/2"MP
6.	HE60	3/8" Pipe Coupler
7.	DWM63	Hydraulic Line
8.	DWM154	Hydraulic Hose 1/4" x 24" 3/8"MP & 3/8"MP
9.	DWM62	Hydraulic Line
10.	DWM135	Orifice .094
11.	BFR122	3/8" Union Adapter
12.	DWM110	3/8" Street Elbow w/90° Swivel
13.	BFR69A	Complete Hydraulic Cylinder
14.	DWM250	Orifice .042
15.	DWM88	Hydraulic Hose 1/4" x 60" 3/8"MP & 3/8"MP
16.	DWM152	Hydraulic Cylinder
17.	DWM89	Hydraulic Hose 1/4" x 78" 3/8"MP & 3/8"MP
18.	DWM381	Hydraulic Hose 1/4" x 90" 3/8"MP & #6SAE O-Ring 90°
19.	DWM382	Hydraulic Hose 1/4" x 96" 3/8"MP & #6SAE O-Ring 90°
20.	DWM156	Hydraulic Hose 1/4" x 56" 3/8"MP & 3/8"MP
21.	DWM383	Hydraulic Hose 1/4" x 66" 3/8"MP & #6SAE O-Ring 90°
22.	DWM155	Hydraulic Hose 1/4" x 38" 3/8"MP & 3/8"MP
23.	DWM269	3/4" Male O-Ring to 3/8" Pipe Union Adapter
24.	DWM268	9/16" Male O-Ring to 3/8" Pipe Union Adapter
25.	DWM388	Electric Solenoid Valve
26.	DWM233	3/8" Union Adapter
27.	DWM384	Hydraulic Hose 1/4" x 78" 3/8"MP & #6SAE O-Ring 90°
28.	23N234	3/8" Street Elbow
29.	16SV351	3/8" Nipple Nut
30.	16SV338	3/8" Ball Valve

FIGURE 9

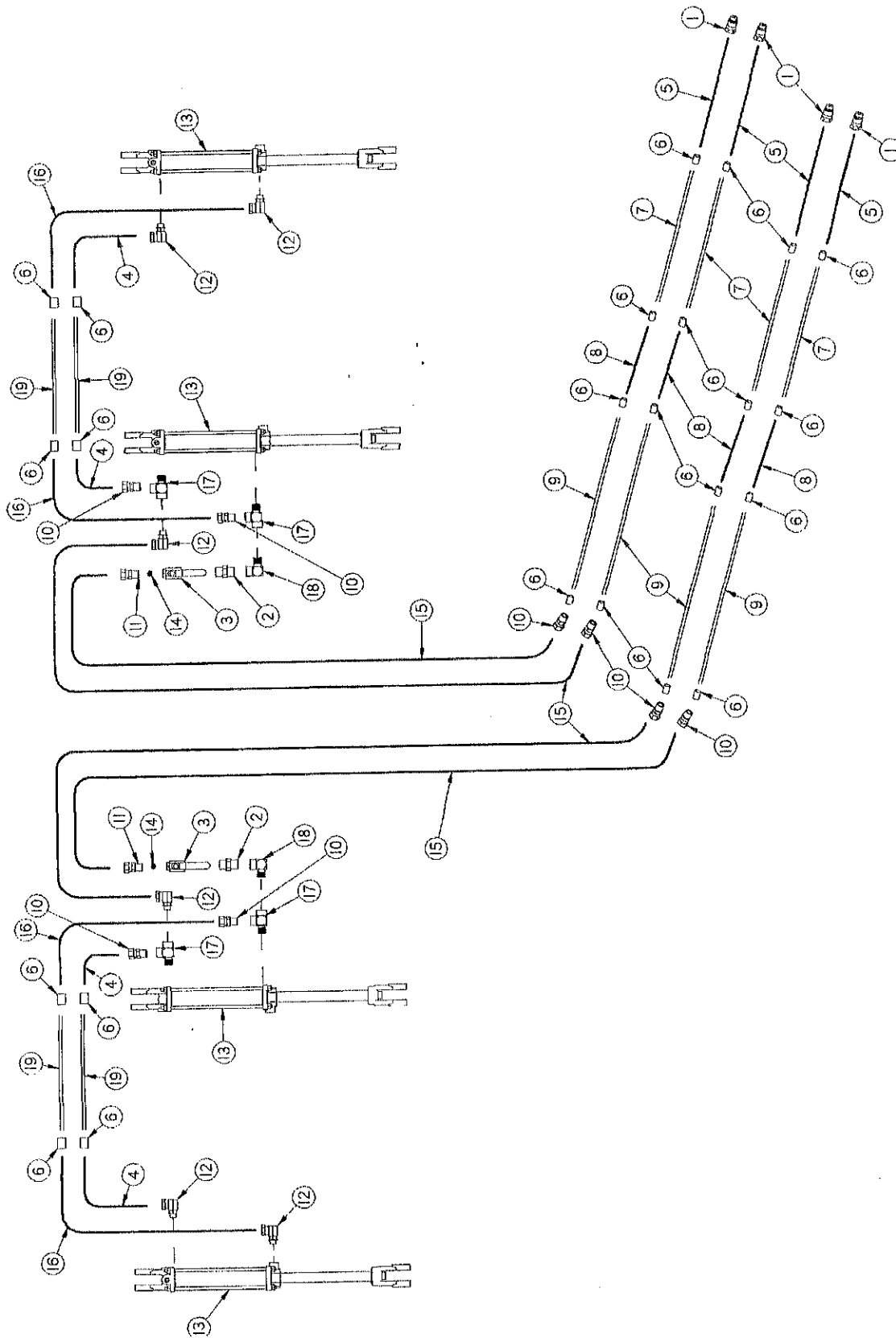

FIGURE 9
H&S 12' TWIN MERGER
HEAD HYDRAULICS

ITEM	PART NO.	DESCRIPTION
1.	DWM205	1/2" Male Quick Coupler
2.	16SV351	3/8" Nipple Nut
3.	16SV338	3/8" Ball Valve
4.	DWM92	Hydraulic Hose 1/4" x 30" 3/8"MP & 3/8"MP
5.	DWM85	Hydraulic Hose 1/4" x 78" 3/8"MP & 1/2"MP
6.	HE60	3/8" Pipe Coupler
7.	DWM63	Hydraulic Line
8.	DWM154	Hydraulic Hose 1/4" x 24" 3/8"MP & 3/8"MP
9.	DWM62	Hydraulic Line
10.	DWM233	3/8" Union Adapter
11.	BFR122	3/8" Adapter Union
12.	DWM110	3/8" Street Elbow w/90° Swivel
13.	BFR69A	Complete Hydraulic Cylinder
14.	BFR120	.062 Restrictor
15.	DWM88	Hydraulic Hose 1/4" x 60" 3/8"MP & 3/8"MP
16.	SHM15	Hydraulic Hose 1/4" x 40" 3/8"MP & 3/8"MP (5000 PSI)
17.	23N116	3/8" Street Tee
18.	23N234	3/8" Street Elbow
19.	DWM416	Head Lift Pipe

FIGURE 10

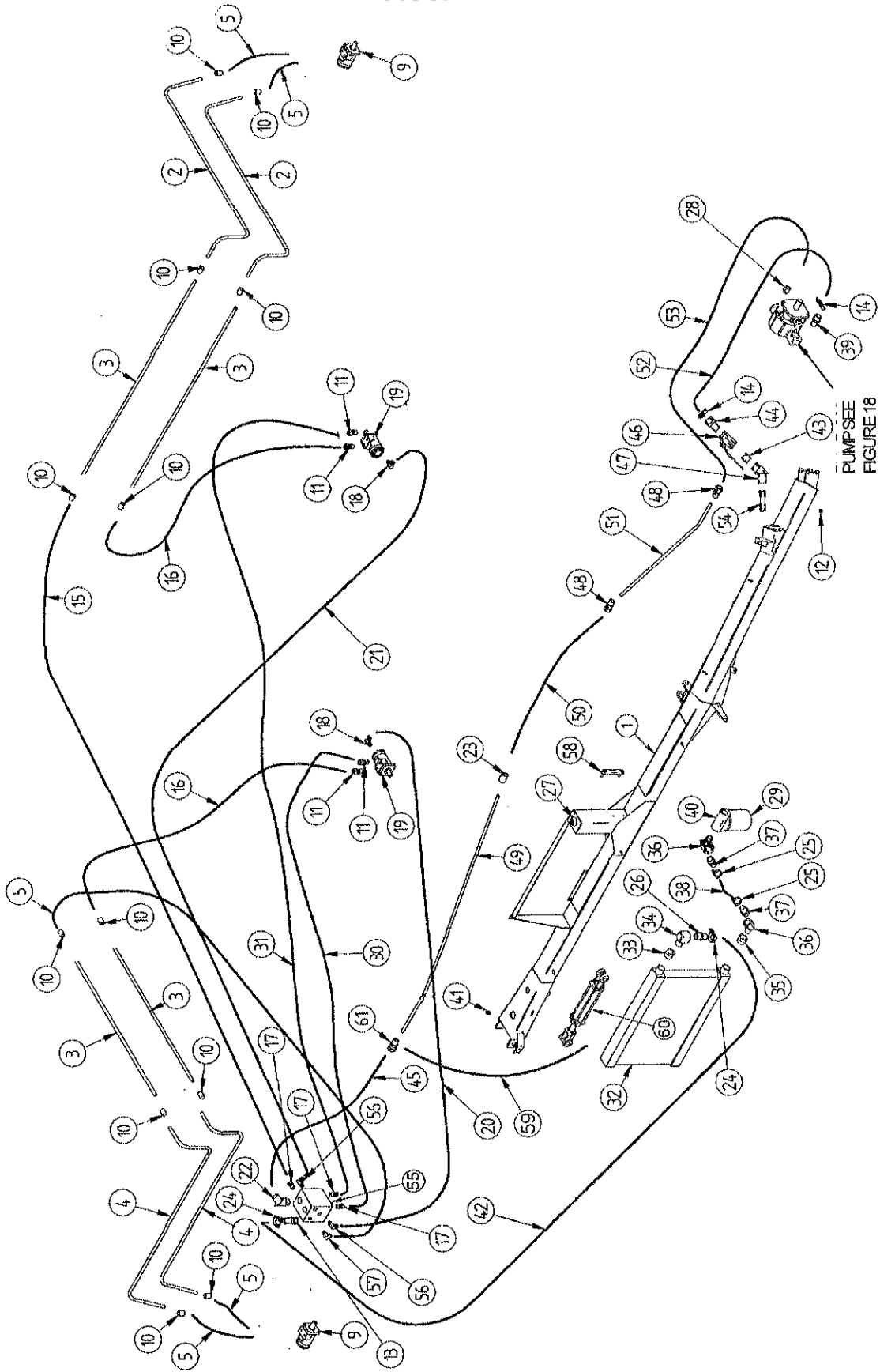

FIGURE 10
H&S 9' & 12' TWIN MERGER
MAIN FRAME HYDRAULICS

ITEM	PART NO.	DESCRIPTION	ITEM	PART NO.	DESCRIPTION
1.	DWM442	Pole Tank	31.	DWM100	Hyd. Hose 1/2"x77" 1/2"MP&1/2"MP
2.	DWM234	Motor Tubing A	**	DWM103	Hyd.Hose1/2"X40"1/2"MPX1/2"MP
3.	DWM235	Motor Pipe	32.	DWM78	Oil Cooler
4.	DWM236	Motor Tubing B	*	DWM319	Fan Assembly
5.	DWM102	Hyd. Hose 1/2"x25" 1/2"MP&1/2"MP	33.	DWM239	1-1/2" to 1" Bushing (Black Iron)
9.	DF1	Cross Conveyor Motor (101-2970)	34.	DWM240	1" Street Elbow (Black Iron)
*	WM225	Seal Kit	35.	DWM241	1-1/2" to 1-1/4" Bushing (Black Iron)
10.	LW346	1/2" Coupler (Black Iron)	36.	DWM242	1-1/4" 45° Street Elbow (Black Iron)
11.	LW174	1/2" Union Adapter	37.	DWM143	1-1/4" Hose Barb
12.	DWM159	3/4" Pipe Plug	38.	DWM95	Hydraulic Hose 1-1/4" x 10"
13.	DWM257	1" Hose Barb	39.	DWM260	Hose Barb
14.	DWM122	2" Hose Clamp	40.	DWM82	Filter Base
15.	DWM103	Hyd. Hose 1/2"x40" 1/2"MP&1/2"MP	41.	DWM261	1" Hex Socketed Pipe Plug
16.	DWM101	Hyd. Hose 1/2"x49" 1/2"MP&1/2"MP	42.	DWM96	Hydraulic Hose 1" x 148"
17.	DWM258	1"-16 O-Ring to 1/2" Pipe Union	43.	DWM147	2" Nipple Nut
18.	DWM119	7/16" to 3/8" 90°Pipe Union	44.	DWM144	2" Hose Barb
19.	DWM84	Pickup Motor (101-3048)	45.	DWM98	Hyd. Hose 1"x48" 1"MP&1"MP
*	WM225	Seal Kit	46.	DWM83	Ball Valve
20.	DWM108	Hyd. Hose 1/4"x56" 3/8"MP&1/2"MP	47.	DWM267	2" - 45° Elbow
**	SHM14	Hyd. Hose 1/4"x30" 3/8"MP&1/2"MP	48.	DWM109	1" Adapter Union
21.	DWM107	Hyd. Hose 1/4"x84" 3/8"MP&1/2"MP	49.	DWM64	1" x 161" Pipe
**	DWM108	Hyd.Hose1/4"X56"3/8"MPX1/2"MP	50.	DWM99	Hyd. Hose 1"x24" 1"MP&1"MP
22.	DWM413	45° Adapter	51.	DWM65	1" x 66" Pipe
23.	DWM146	1" Coupling	52.	DWM262	Suction Hose 2" x 50"
24.	DWM123	1" Hose Clamp	53.	DWM263	Two Wire Hyd. Hose 1" x 60"
25.	DWM138	1-1/4" Hose Clamp	54.	DWM80	2" Strainer
26.	DWM145	1" Hose Barb	55.	DWM264	Flow Divider
27.	DWM81	Strainer Filler	*	DWM401	Relief Valve Cartridge
28.	DWM259	1-5/8" O-Ring to 1" Pipe Connector	56.	DWM265	3/4" O-Ring to 3/8" Pipe 90° Adp.
29.	STM23	Filter	57.	DWM266	1-1/16" O-Ring to 1/2" Pipe Adp.
30.	DWM105	Hyd. Hose 1/2"x63" 1/2MP&1/2"MP	58.	DWM204	Temp. & Oil Level Gauge
**	DWM102	Hyd. Hose 1/2"x25" 1/2"MP&1/2"MP	59.	DWM363	Hose 1/4" x 31.25"
NOTE: *	(MEANS NOT SHOWN)		60.	T188A	Hydraulic Cylinder 2-1/2" x 8"
**	(12' TWIN MERGER ONLY)		61.	DWM365	1" Adapter Union w/Hole

FIGURE 11

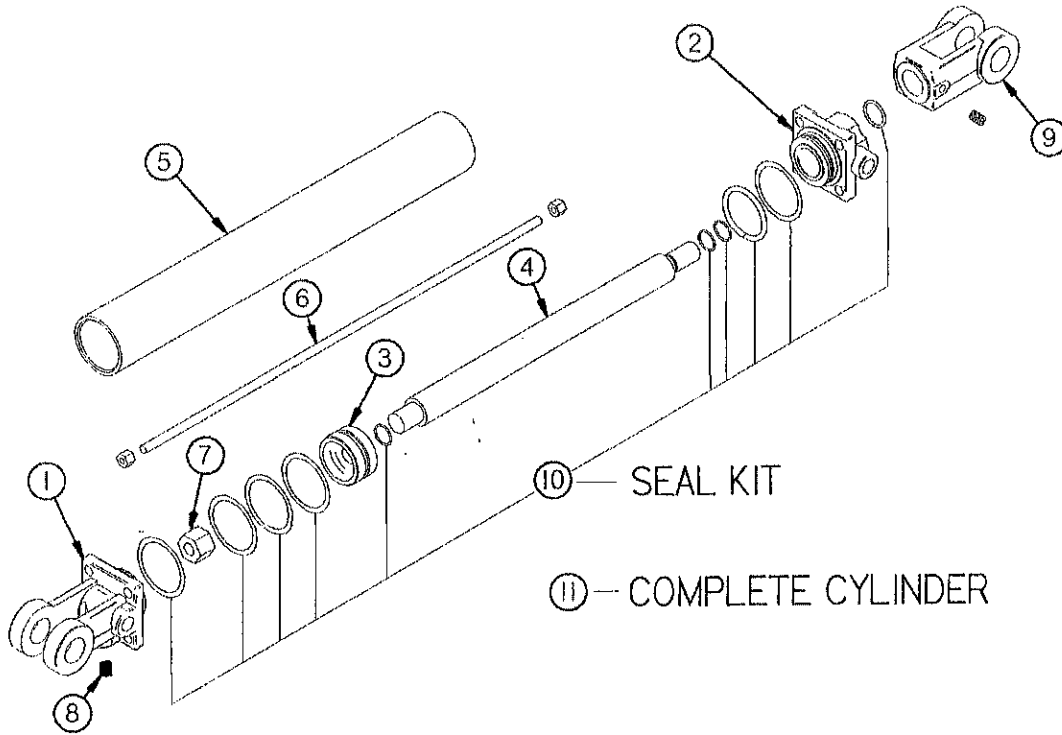

FIGURE 11
H&S 9' & 12' TWIN MERGER PICK-UP HEAD 2" x 8"
HYDRAULIC CYLINDER

ITEM	PART NO.	DESCRIPTION
1.	23N142A	Clevis Cap
2.	23N143A	Rod Cap
3.	23N144	Piston
4.	T134A	Rod
5.	BFR68	Cylinder Tube
6.	T186	Tie Rod
7.	23N148	Piston Nut
8.	23N149	Plug
9.	23N150A	Rod Clevis
10.	23N151	Seal Kit
11.	BFR69A	Complete Cylinder

FIGURE 12

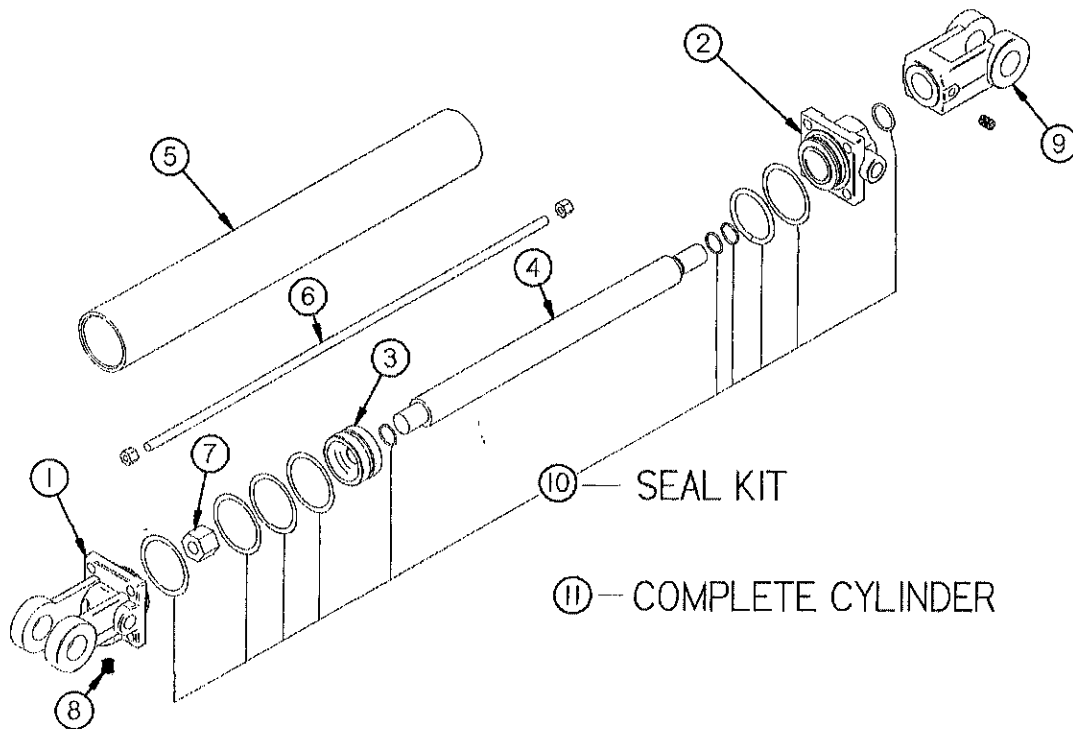

FIGURE 12
H&S 9' & 12' TWIN MERGER POLE 3-1/2" x 30"
HYDRAULIC CYLINDER

ITEM	PART NO.	DESCRIPTION
1.	DWM417	Clevis Cap
2.	DWM418	Rod Cap
3.	DWM419	Piston
4.	DWM420	Rod
5.	DWM421	Cylinder Tube
6.	DWM422	Tie Rod
7.	DWM423	Piston Nut
8.	DWM424	Plug
9.	DWM425	Rod Clevis
10.	DWM426	Seal Kit
11.	DWM406	Complete Cylinder

FIGURE 13

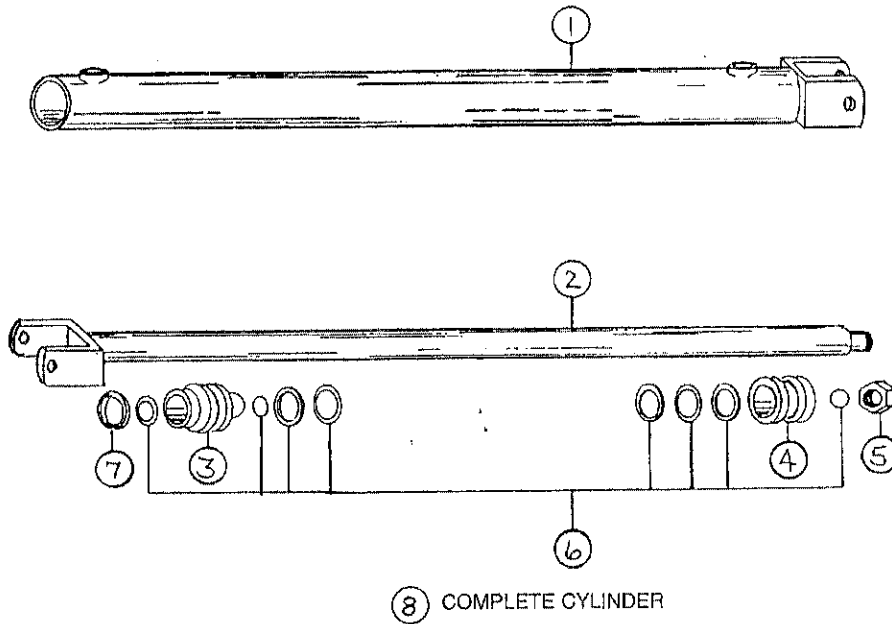

FIGURE 13
H&S 9' TWIN MERGER HEAD SHUTTLE 2" x 38"
HYDRAULIC CYLINDER

ITEM	PART NO.	DESCRIPTION
1.	DWM202	Case Weldment
2.	DWM203	Rod Weldment
3.	BFR330	Head Gland
4.	BFR331	Piston
5.	BFR332	Jam Nut
6.	BFR333	Seal Kit
7.	BFR334	Snap Ring
8.	DWM152	Complete Cylinder

FIGURE 14

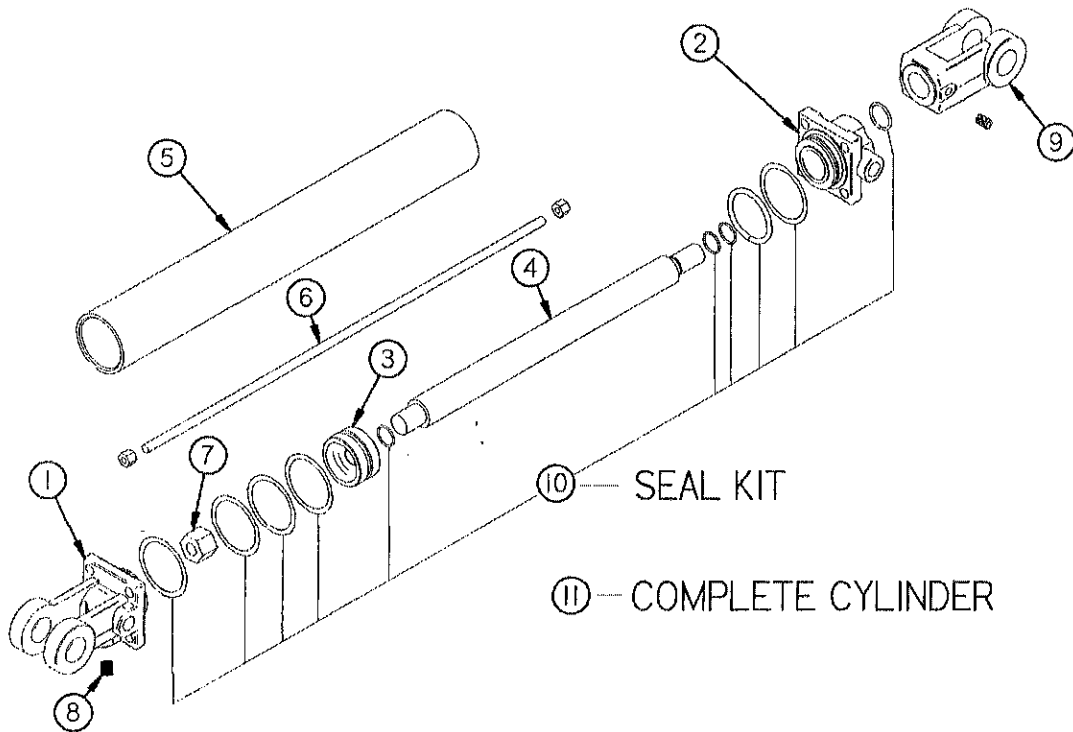

FIGURE 14
H&S 9' & 12' TWIN MERGER LOAD LEVELER 2-1/2" x 8"
HYDRAULIC CYLINDER

ITEM	PART NO.	DESCRIPTION
1.	T181A	Clevis Cap
2.	T182A	Rod Cap
3.	T183	Piston
4.	T184A	Rod
5.	T185	Cylinder Tube
6.	T186	Tie Rod
7.	23N148	Piston Nut
8.	23N149	Plug
9.	23N150A	Rod Clevis
10.	T187	Seal Kit
11.	T188A	Complete Cylinder

FIGURE 15

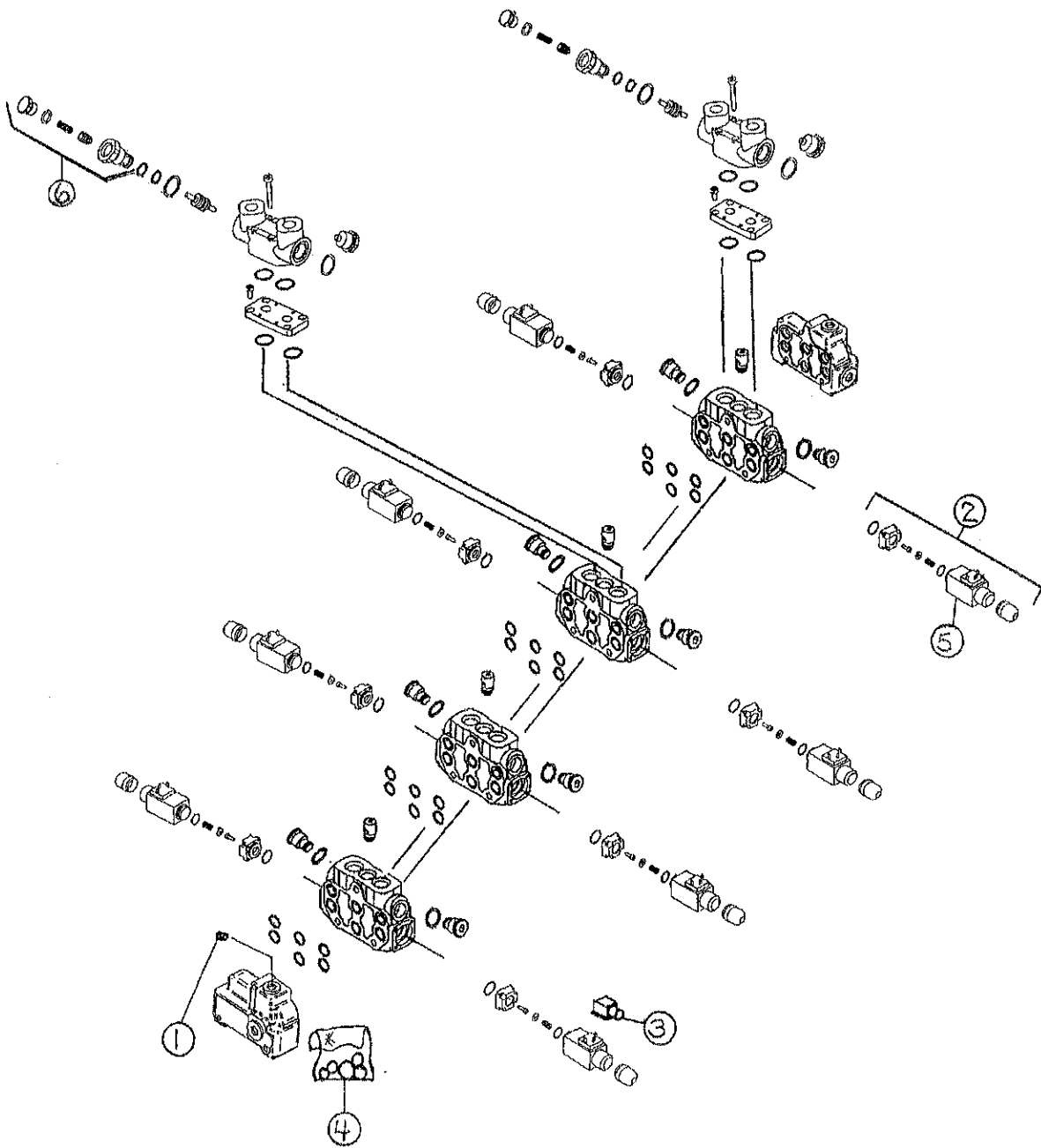

FIGURE 15
H&S 9' TWIN MERGER ELECTRIC/HYDRAULIC
VALVE BREAKDOWN

ITEM	PART NO.	DESCRIPTION
1.	DWM389	Close Center Plug
2.	DWM390	Solenoid Assembly
3.	DWM305	Din Connector
4.	DWM391	Seal Kit
5.	DWM392	Solenoid Block & Pin
6.	DWM393	Check Valve Repair Kit
*	DWM388	Complete Valve

NOTE: * (MEANS NOT SHOWN)

FIGURE 16

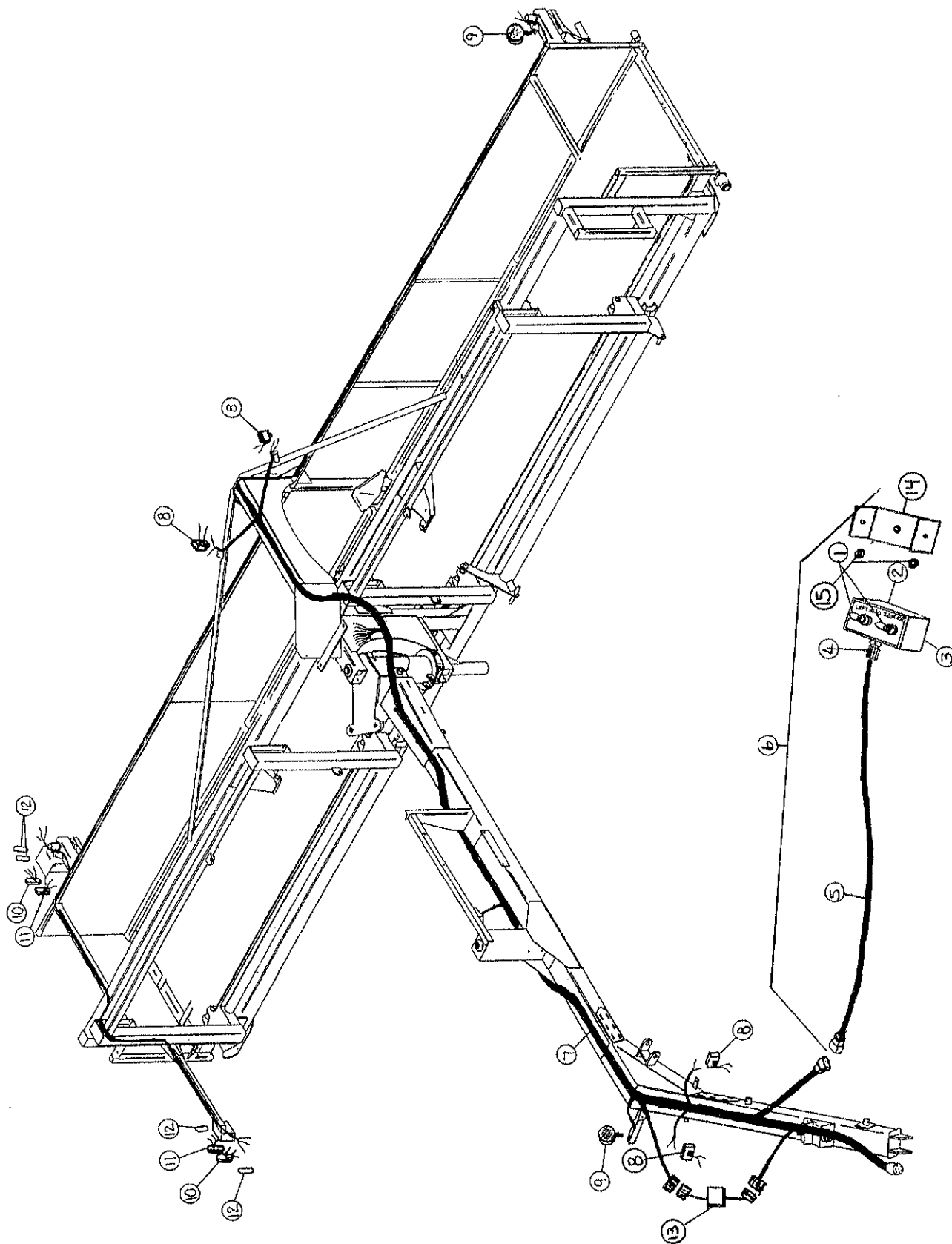

FIGURE 16
H&S 9' & 12' TWIN MERGER
ELECTRIC WIRING HARNESS

ITEM	9' HEAD	12' HEAD	DESCRIPTION
1.	DWM174	-	Joy Stick & Switch
2.	DWM139	-	Control Box Top
3.	DWM140	-	Control Box Bottom
4.	DWM175	-	Strained Relief (Cord Grip)
5.	WMC2A	-	Cord
6.	DWM167	-	Complete Control Box
7.	DWM362	SHM16	Main Wiring Harness
8.	DWM130	"	Flood/Work Lights
9.	DWM129	"	Yellow Hazard Lights
10.	DWM131	"	Yellow Tail Lights
11.	S310	"	Red Tail Lights
12.	S308	"	Rubber Light Mount
13.	S441	"	Light Module
14.	DWM326	-	Control Box Yoke
15.	DWM327	-	Poly Washer
*	DWM406	-	Knob (2)
*	DWM404	-	Rubber Washer (2)

NOTE: - (MEANS NOT USED ON THIS MODEL)
" (MEANS SAME PART AS PREVIOUS MODEL)
*** (MEANS NOT SHOWN)**

FIGURE 17

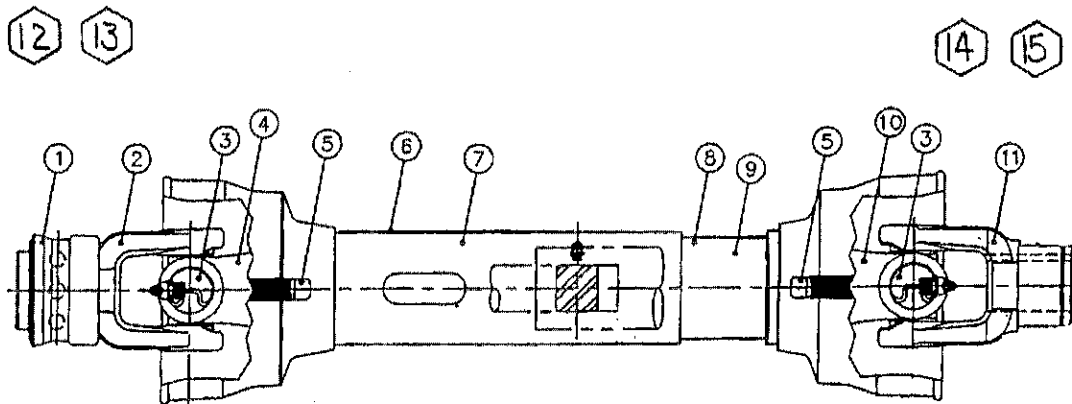

FIGURE 17
H&S 9' & 12' TWIN MERGER
PTO ASSEMBLY

ITEM	PART NO.	DESCRIPTION
1.	S225	Spring Lock Repair Kit
2.	37N73	Spring Lock Yoke Assembly #14121-1012
3.	14NWKIT	Cross & Bearing Kit (14R)
4.	DWM289	Yoke & Shaft
5.	4N20	Nylon Repair Kit
6.	DWM290	Safety Sign
7.	DWM291	Outer Guard
8.	DWM292	Inner Guard
9.	DWM293	Safety Sign (Not Shown)
10.	DWM294	Yoke, Tube & Slip Sleeve
11.	DWM295	Yoke
12.	DWM296	Joint & Shaft Half Assembly w/Guard
13.	DWM297	Joint & Shaft Half Assembly
14.	DWM298	Joint & Tube Half Assembly w/Guard
15.	DWM299	Joint & Tube Half Assembly
*	DWM300	Complete PTO

NOTE: * (MEANS NOT SHOWN)

FIGURE 18

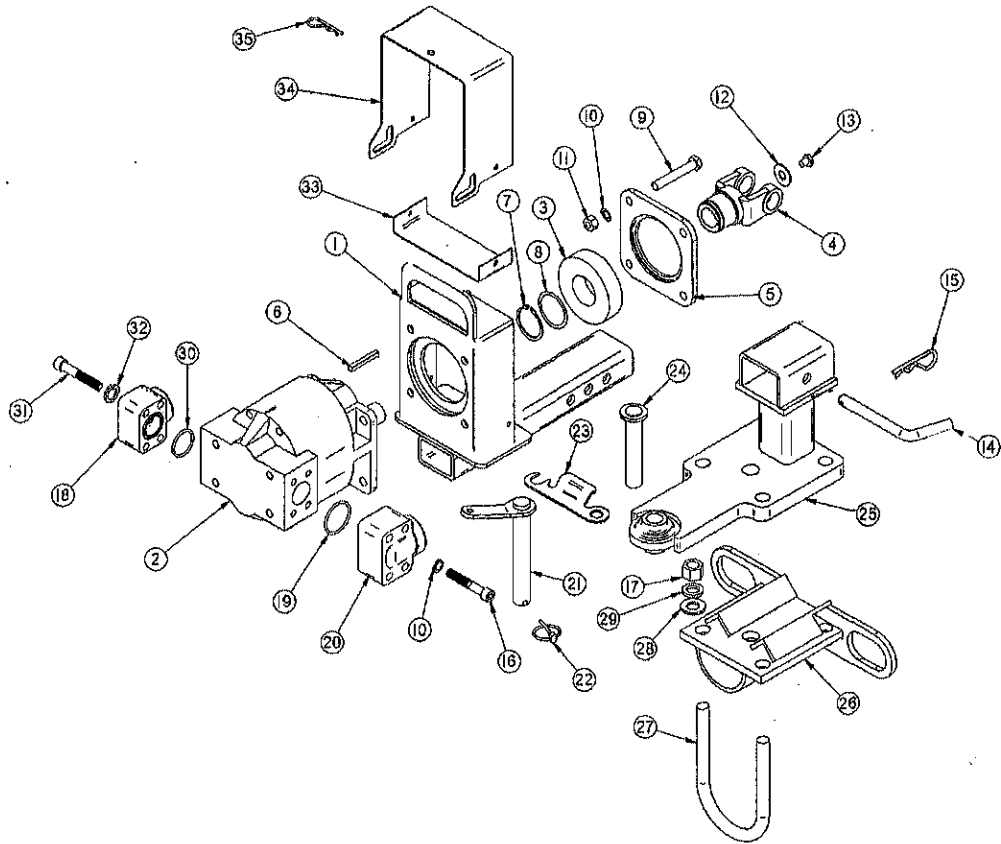
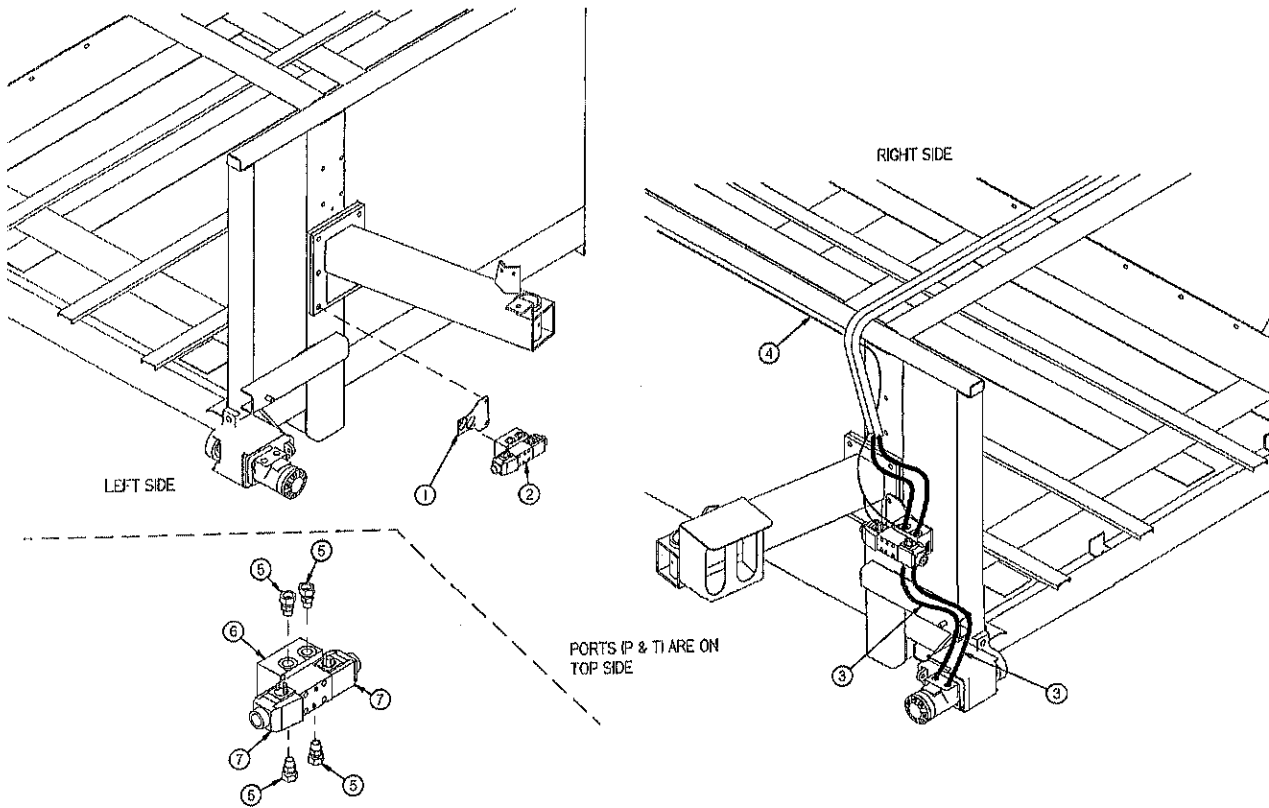

FIGURE 18
H&S 9' & 12' TWIN MERGER
HITCH ASSEMBLY

ITEM	PART NO.	DESCRIPTION	ITEM	PART NO.	DESCRIPTION
1.	DWM336	Receiver Pump Mount	18.	DWM283	Pressure L-Flange
2.	DWM276	PTO Pump	19.	DWM284	O-Ring
*	DWM302	Replacement Shaft Seal	20.	DWM285	Return L-Flange
3.	DWM277	Thrust Roller Bearing	21.	DWM273	Draw Pin
4.	DWM295	PTO Yoke (See Figure 17)	22.	F56	Clip Pin
5.	DWM278	Outside Bearing Housing	23.	DWM286	Drawbar Pin Lock
6.	DWM279	5/16"x2-1/4" Key (Round Edges)	24.	DWM274	Hitch Pin
7.	DWM280	Snap Ring 2"	25.	DWM271	Hitch Extension
8.	G92	Shim (As Needed)	26.	DWM272	Hitch Plate
9.	16SV91	1/2" x 3-1/4" Bolt GR. 5	27.	DWM287	U-Bolt (2)
10.	R35	1/2" Lock Washer	28.	DWM288	3/4" Flat Washer
11.	R29	1/2" Nut	29.	RG199	3/4" Lock Washer
12.	DWM320	1/2" Flat Washer	30.	DWM311	O-Ring
13.	DWM301	Bolt - Metric	31.	DWM312	7/16" Socket Head Cap Screw
14.	10WR14	5" Bent Pin	32.	DWM313	7/16" Lock Washer
15.	DWM310	Hair Pin	33.	DWM330	Lower PTO Shield
16.	DWM281	1/2" Socket Head Cap Screw	34.	DWM329	Upper PTO Shield
17.	DWM282	3/4" Nut	35.	X97	Hair Pin

NOTE: * (MEANS NOT SHOWN)

FIGURE 19



**FIGURE 19
H&S 9' & 12' TWIN MERGER
CROSS CONVEYOR DIRECTION VALVE**

ITEM	PART NO.	DESCRIPTION
1.	DWM450	Conveyor Reverse Bracket
2.	DWM446	Valve (Complete)
3.	DWM104	Hydraulic Hose 1/2" X 19" - 1/2 MP X 1/2" MP
4.	DWM445	Wiring Harness
5.	DWM454	Union Adapter (6900-8-8)
6.	DWM457	Valve Base
7.	DWM458	Coil

FIGURE 20

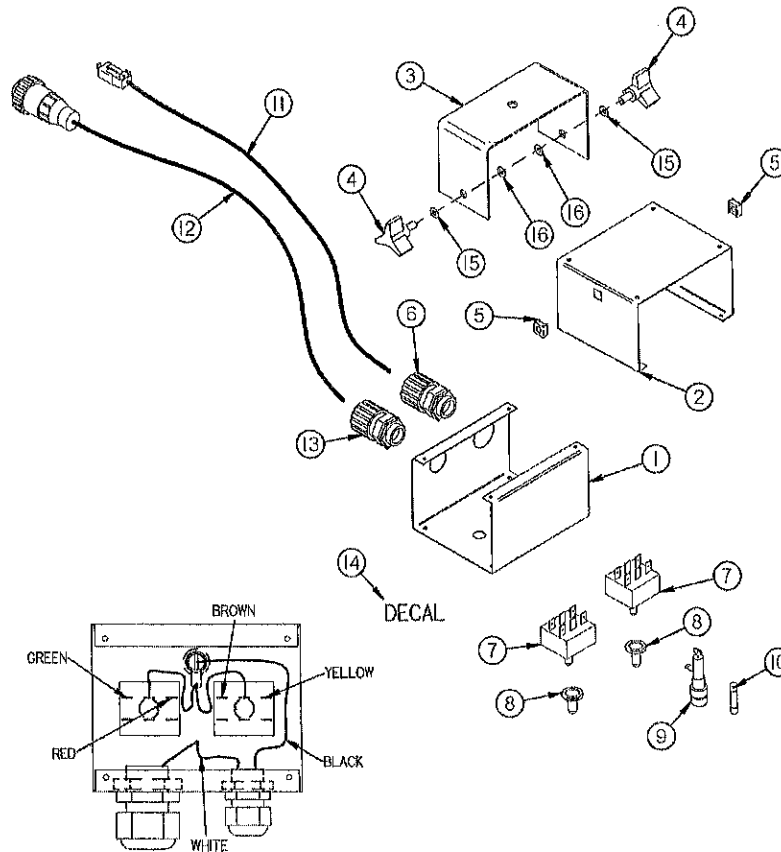

FIGURE 20
H&S 9' & 12' TWIN MERGER
CROSS CONVEYOR CONTROL BOX

ITEM	PART NO.	DESCRIPTION
1.	DWM447	Control Box Top
2.	DWM448	Control Box Bottom
3.	DWM449	Control Box Mount
4.	HD174	Knob
5.	HD173	Panel Nut
6.	DWM455	Strain Relief
7.	DWM453	Switch (Hesitation)
8.	16SV235	Switch Boot
9.	16SV231	Fuse Holder
10.	DWM456	Fuse (15 Amp)
11.	DWM444	Implement Cord
12.	16SV271	Power Cord
13.	16SV316	Strain Relief (Cord Grip)
14.	120406	Decal
15.	DWM327	Poly Washer
16.	DWM404	Rubber Washer
*	DWM452	Complete Cross/Reverse Box

NOTE: * (MEANS NOT SHOWN)

FIGURE 22

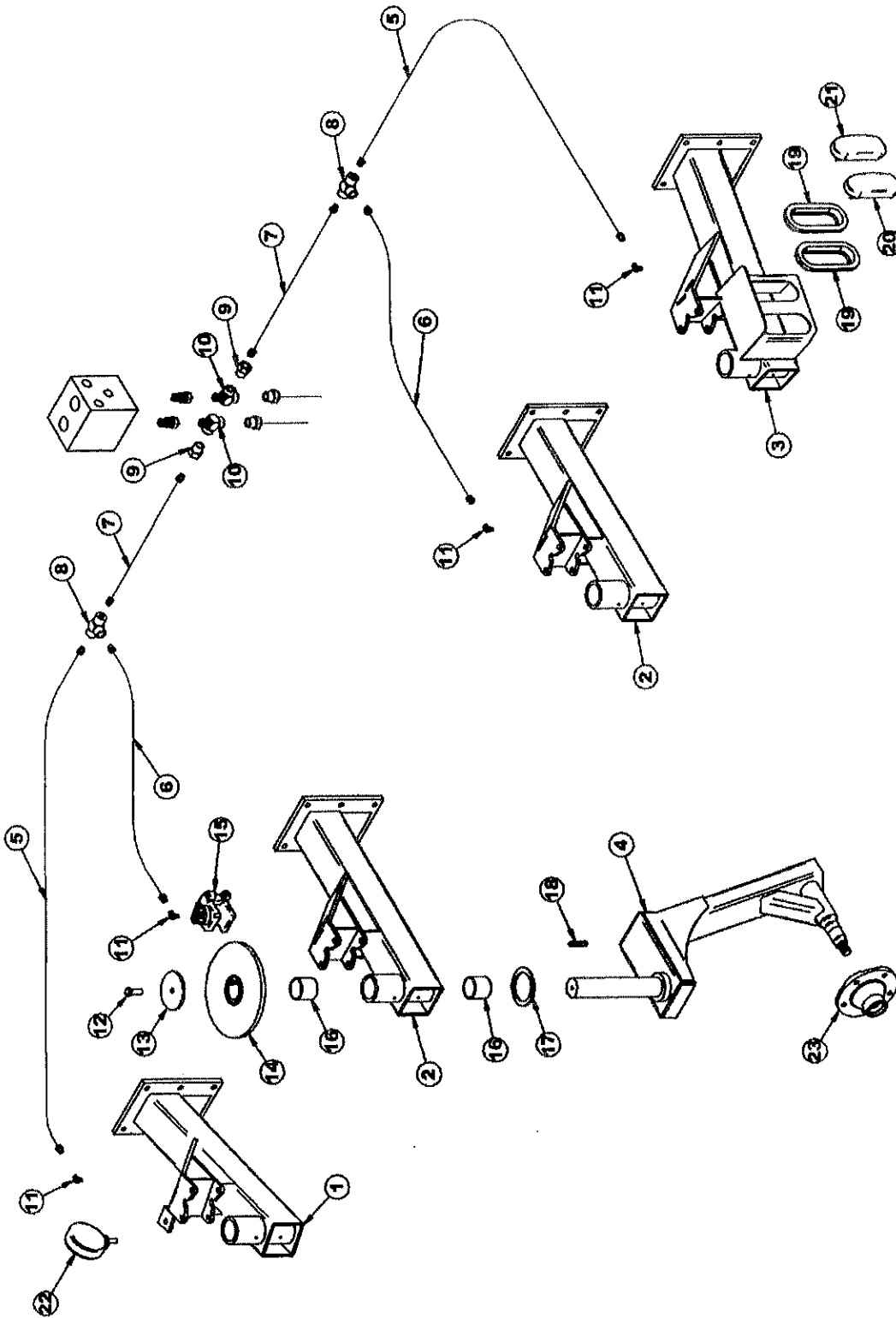

FIGURE 22
H&S 9' & 12' TWIN MERGER
OPTIONAL REAR HYDRAULIC BRAKES

ITEM	PART NO.	DESCRIPTION
1.	SHM24	Left Tail Wheel Mount
2.	SHM25	Middle Tail Wheel Mount
3.	SHM26	Right Tail Wheel Mount
4.	SHM27	Caster
5.	SHM28	1/8"x96" Female JIC & #4 Female JIC Hose
6.	SHM29	1/8"x36" Female JIC & #4 Female JIC Hose
7.	SHM30	1/8"x220" Female JIC & #4 Female JIC Hose
8.	SHM31	Tee (JTX)
9.	SHM32	Adapter (4-8FTX)
10.	LW96	1/2" Street Tee
11.	CHM165	Elbow (4 C50X-S)
12.	RG135	Bolt 1/2"x1" GR.5
13.	CHM5	Top Washer
14.	SHM33	Brake Rotor
15.	CHM103	Brake Caliper
*	CHM104	Brake Pad
16.	BFR527	Bushing 2" IDx2-1/4" OD x2"
17.	RG24	Bronze Washer 2" IDx3" ODx1/8"
18.	S38	Square Key 3/8"x2-3/8"
19.	S308	Rubber Light Mount
20.	S309	Yellow Tail Light
21.	S310	Red Tail Light
22.	DWM129	Yellow Hazard Light
23.	RG101	Hub
*	RG98	Seal
*	RG99	Inner Bearing
*	RG100	Inner Race
*	RG102	Stud Bolt
*	BFR144	Nut
*	RG47	Outer Race
*	RG48	Outer Bearing
*	DWM121	Washer (Hardened)
*	RG103	Hub Cap
*	12N24	Wheel (Front & Rear)
*	DWM163	11L x 15 Rear Tire

NOTE: * (MEANS NOT SHOWN)

